

Exotic and Conventional Quarkonium Physics Prospects at Belle II

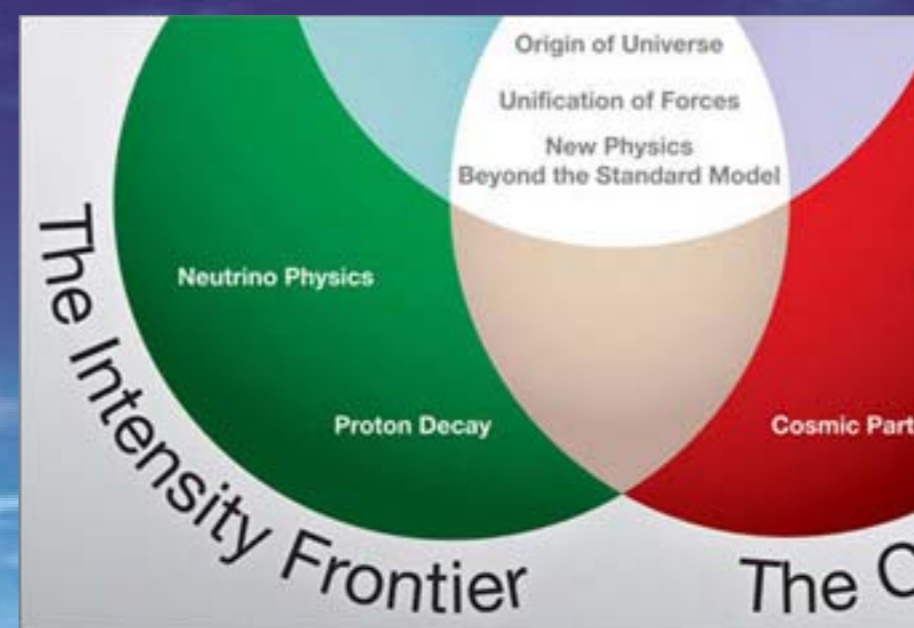

Vladimir Savinov (University of Pittsburgh), on behalf of Belle II Collaboration

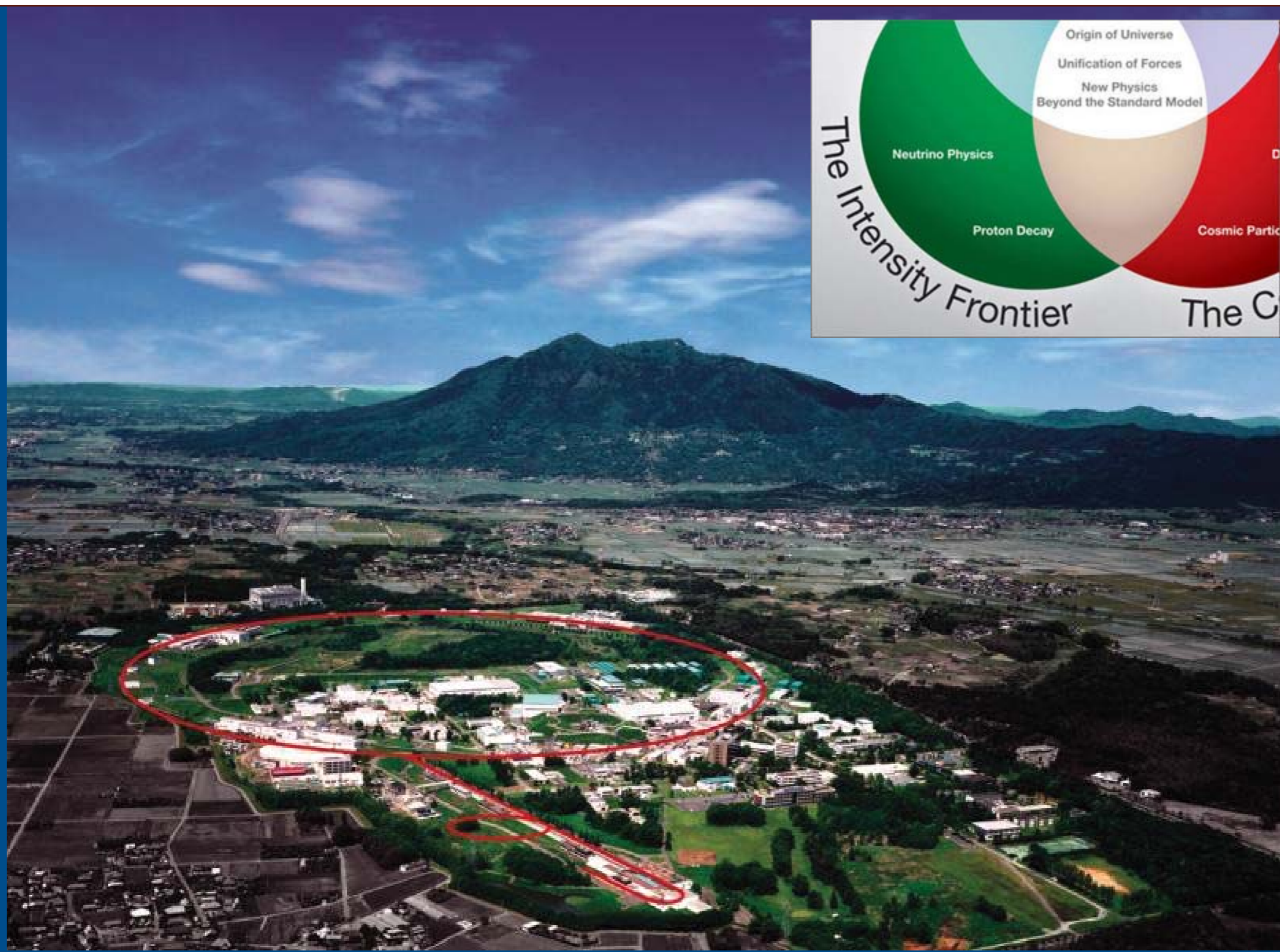
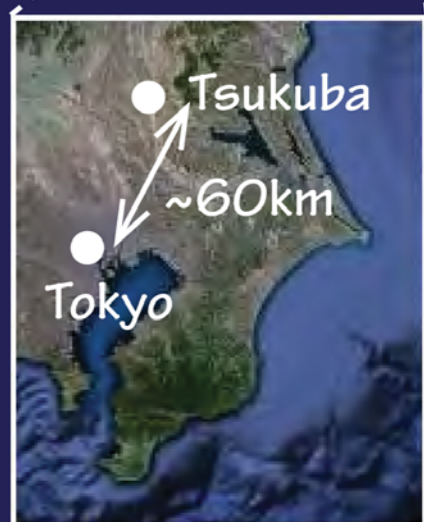

Belle II @ Super-KEKB



Intensity frontier B-factory experiment, successor to Belle @ KEKB (1999-2010)

7 GeV e⁻, 4 GeV e⁺
E_{CM} = 10.58 GeV

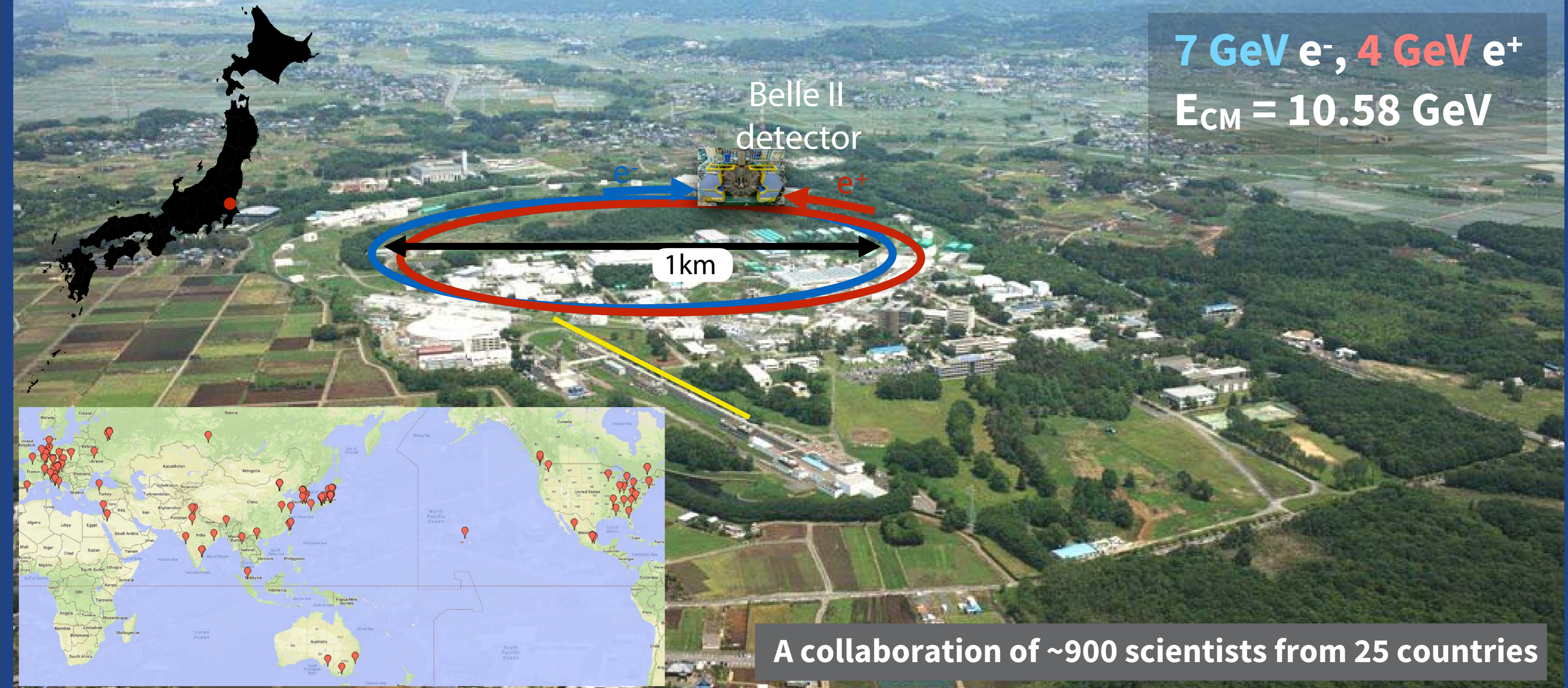

A collaboration of ~900 scientists from 25 countries

The Belle II detector

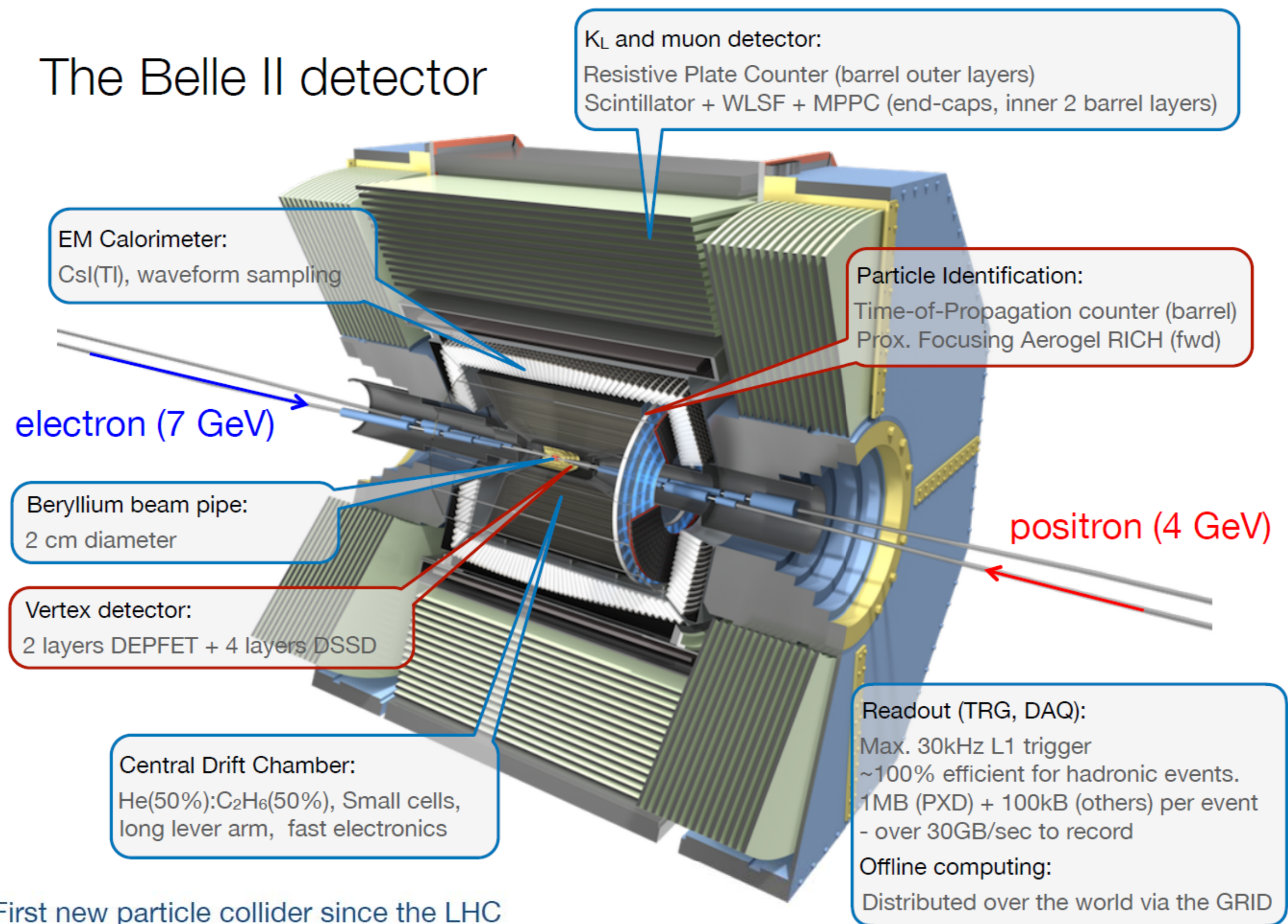

K_L and muon detector:
Resistive Plate Counter (barrel outer layers)
Scintillator + WLSF + MPPC (end-caps, inner 2 barrel layers)

EM Calorimeter:
CsI(Tl), waveform sampling

Particle Identification:
Time-of-Propagation counter (barrel)
Prox. Focusing Aerogel RICH (fwd)

electron (7 GeV)

Beryllium beam pipe:
2 cm diameter

positron (4 GeV)

Vertex detector:
2 layers DEPFET + 4 layers DSSD

Central Drift Chamber:
He(50%):C₂H₆(50%), Small cells,
long lever arm, fast electronics

Readout (TRG, DAQ):
Max. 30kHz L1 trigger
~100% efficient for hadronic events.
1MB (PXD) + 100kB (others) per event
- over 30GB/sec to record
Offline computing:
Distributed over the world via the GRID

First new particle collider since the LHC
(intensity rather than energy frontier; e⁺e⁻ rather than pp)

arXiv:1011.0352 [physics.ins-det]

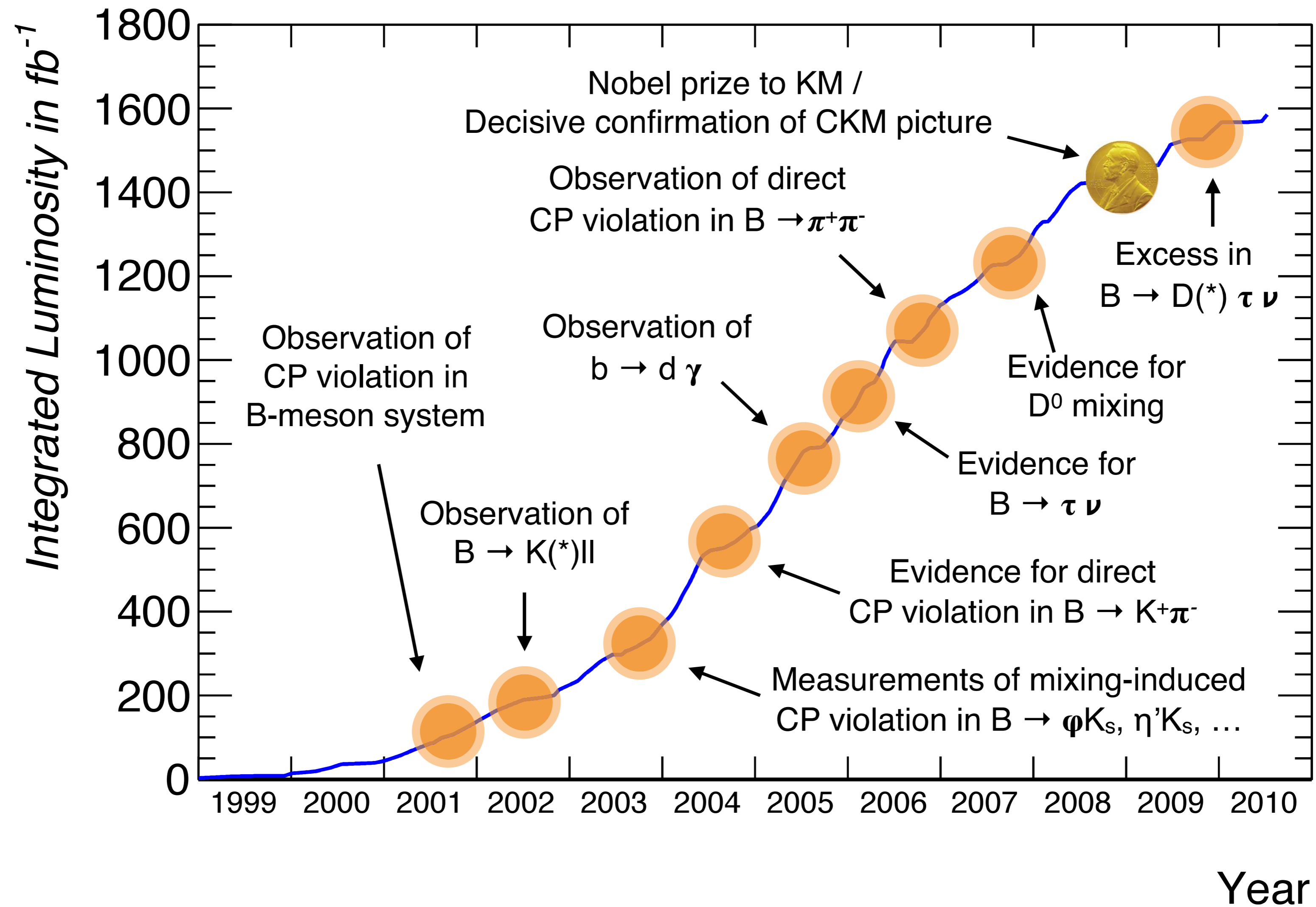

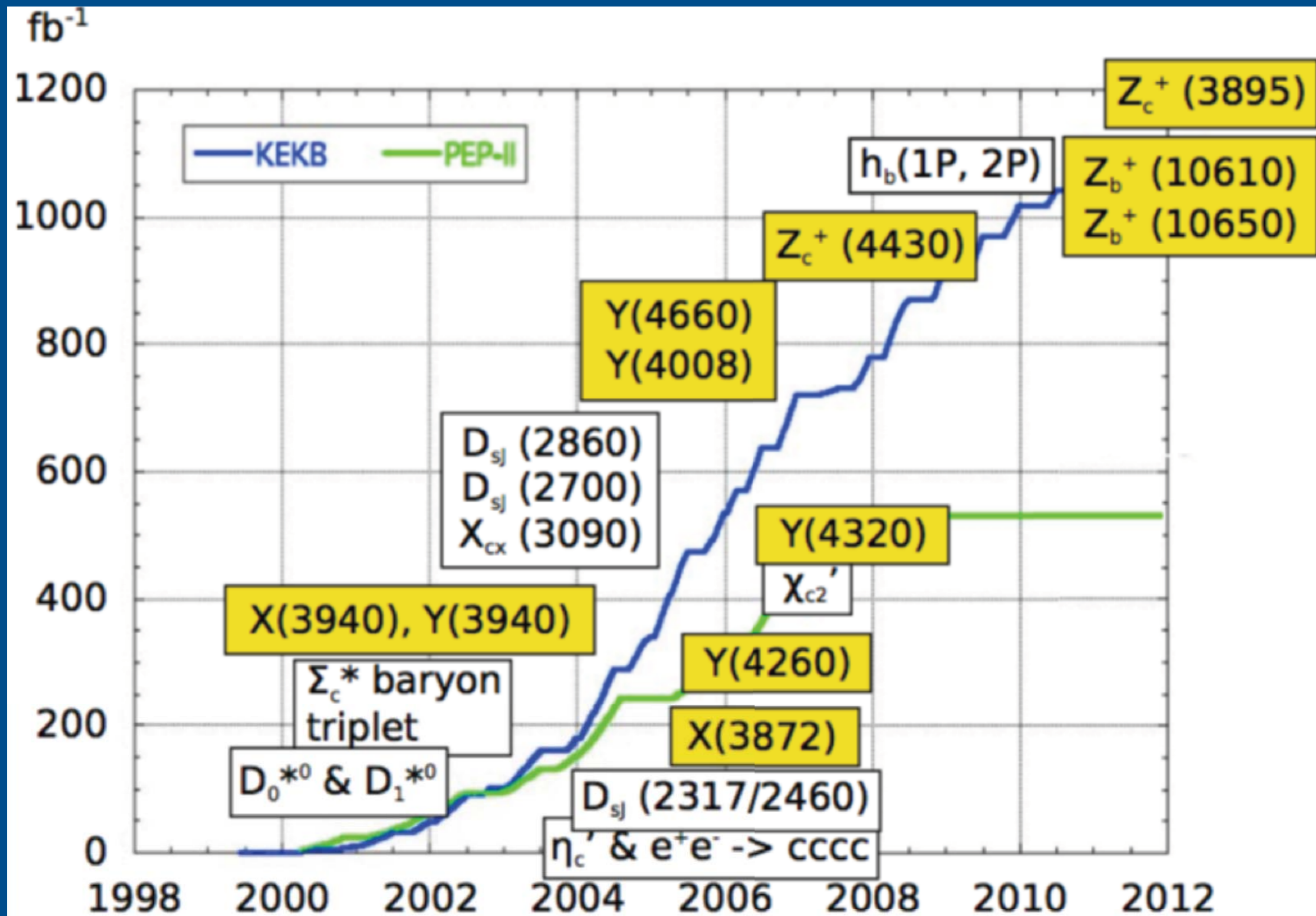

And Now For Something Completely Different

QCD@LHC 2019 QCD@LHC 2019

Scientific Programme

PQCD/MC

Perturbative QCD and Monte Carlo event generators.

Heavy Flavor/Top

Heavy Flavor and Top quark physics

Higgs/EW/BSM

Higgs Electroweak and BSM physics

PDFs/alpha_S/Soft

Parton Distribution Functions, studies of strong coupling and Soft physics

Jets/Substructure/Resummation

Jets their properties and Resummation calculations.

REVIEWS OF MODERN PHYSICS, VOLUME 90, JANUARY–MARCH 2018

Nonstandard heavy mesons and baryons: Experimental evidence

Stephen Lars Olsen*

Center for Underground Physics, Institute for Basic Science, Daejeon 34126 Korea

Tomasz Skwarnicki†

Department of Physics, Syracuse University, Syracuse, New York 13244, USA

Daria Zieminska‡

Department of Physics, Indiana University, Bloomington, Indiana 47405-71055, USA

“This nearly total disconnect between the hadrons that we observe in experiments and the quarks and gluons that appear in the theory is a problem of large proportions in particle physics.³ This is what we refer to as the “**QCD dilemma**.” In addition to the intellectual dissatisfaction with a theory that is not directly applicable to the particles that are used and detected in experiments, there is also **a practical problem in that many SM tests and searches for new physics (NP) involve strongly interacting hadrons in the initial and/or final states of the associated measurements.**”

³As Frank Wilczek put it in a recent interview ([Wilczek, 2016](#)): “We have something called a standard model, but its foundations are kind of scandalous. We have not known how to define an important part of it mathematically rigorously,…”



MODELS FOR NONSTANDARD HADRONS

(from Olsen, Skwarnicki, and Zieminska, REVIEW OF MODERN PHYSICS, VOLUME 90, JANUARY–MARCH 2018)

QCD-color-motivated models

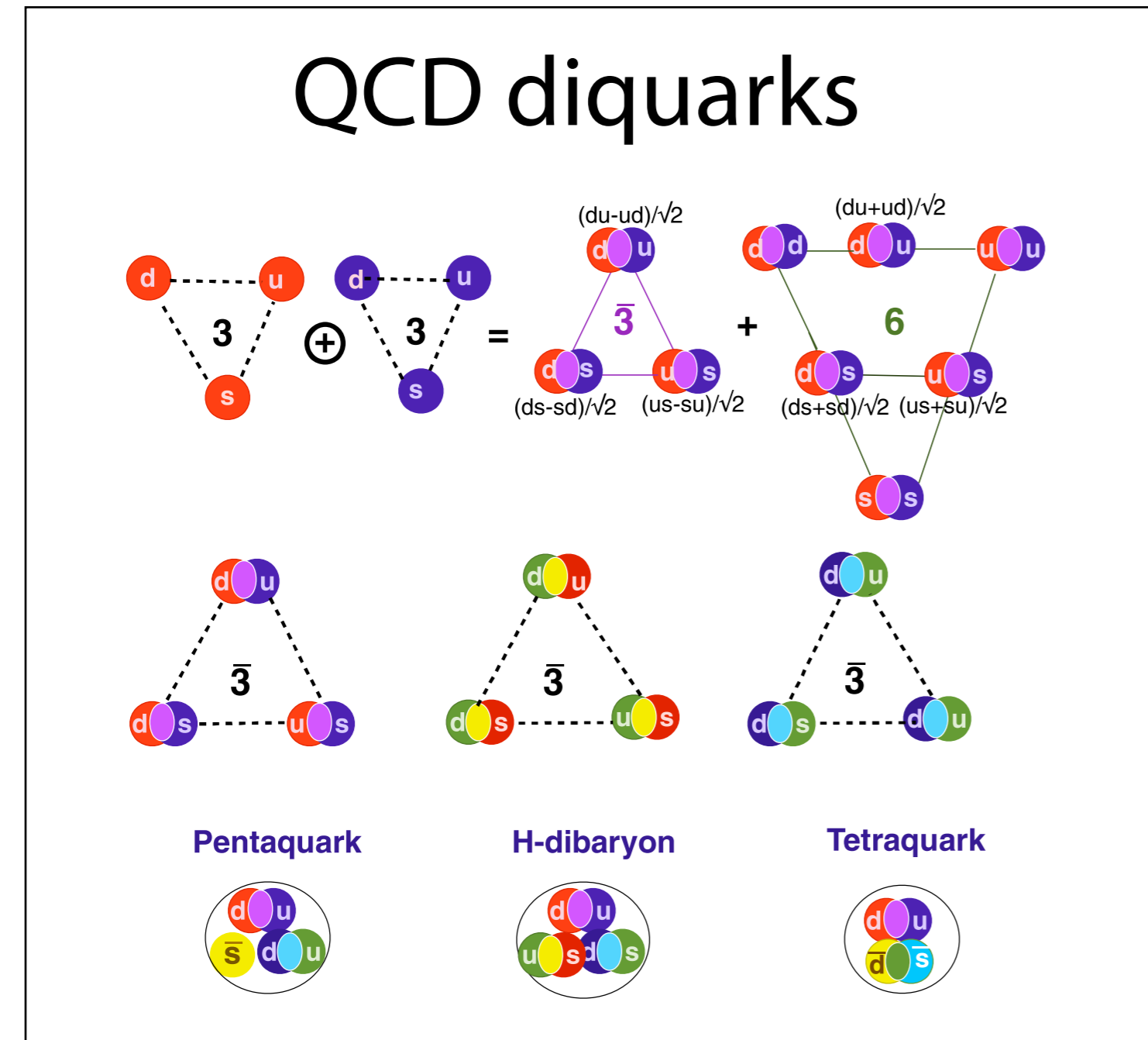

+QCD hybrids (also glueballs)

Other models

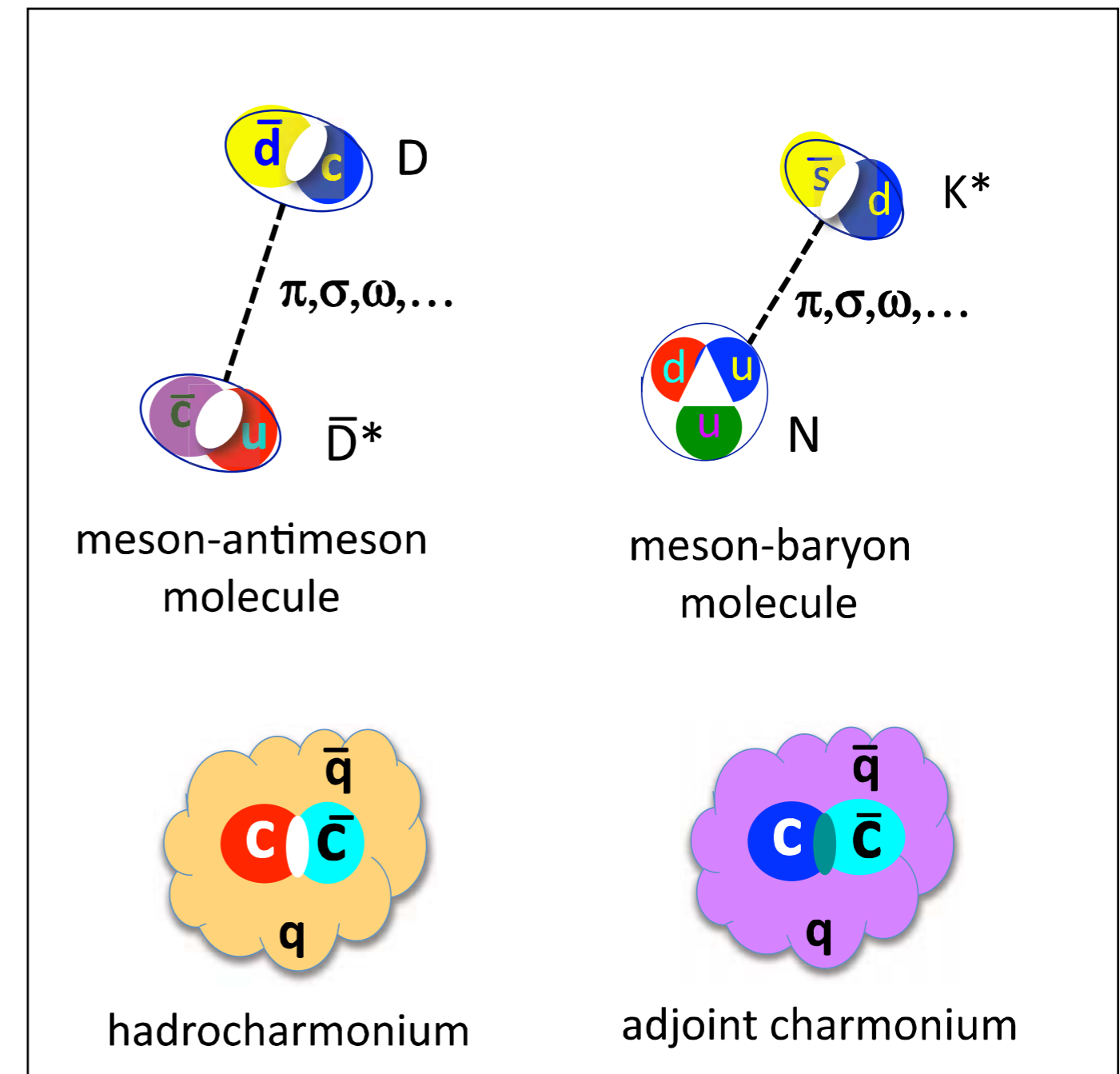

+Kinematically induced resonance-like mass peaks (such as, e.g. threshold cusps)

Lattice QCD should (in principle) be able to predict all colorless states and effects but huge amount of resources would be needed

Still Crazy (about non-perturbative QCD) After All These Years

Currently, **none of the models provide a unified description** of observations!

Some states (e.g. famous $X(3872)$) are best described by a “**mixture of models**”

One of Belle II goals is to provide high-statistics data on hadronic resonances to help theoretical community to develop a unified description of data

A better understanding of non-perturbative QCD remains to be important, topical and necessary after all these years

Renaissance of QCD and Hadron Spectroscopy

XYZ Discoveries at Belle

Active data analysis and discoveries continue!

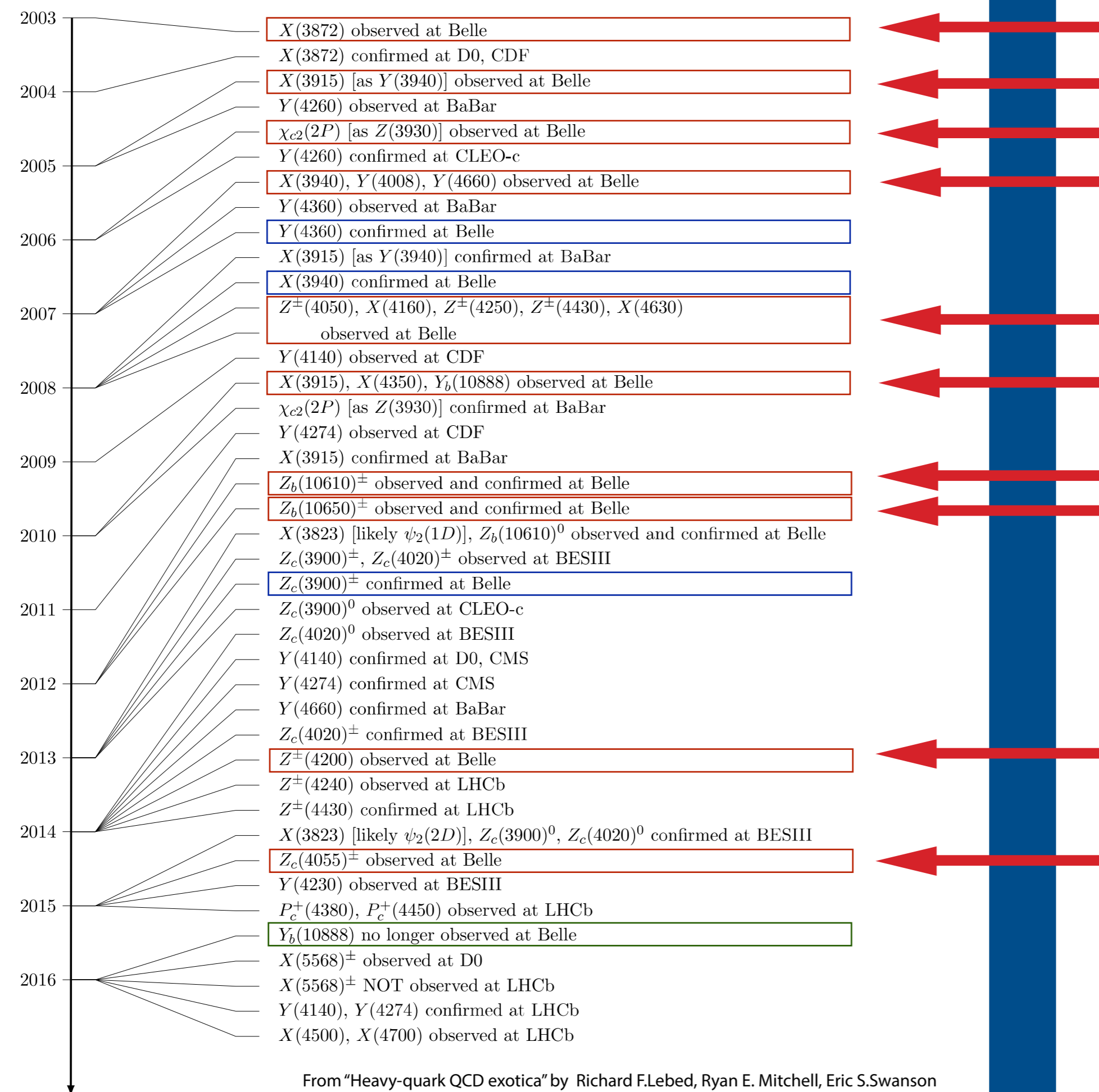

From "Heavy-quark QCD exotica" by Richard F. Lebed, Ryan E. Mitchell, Eric S. Swanson
Progress in Particle and Nuclear Physics, Volume 93, March 2017, Pages 143-194

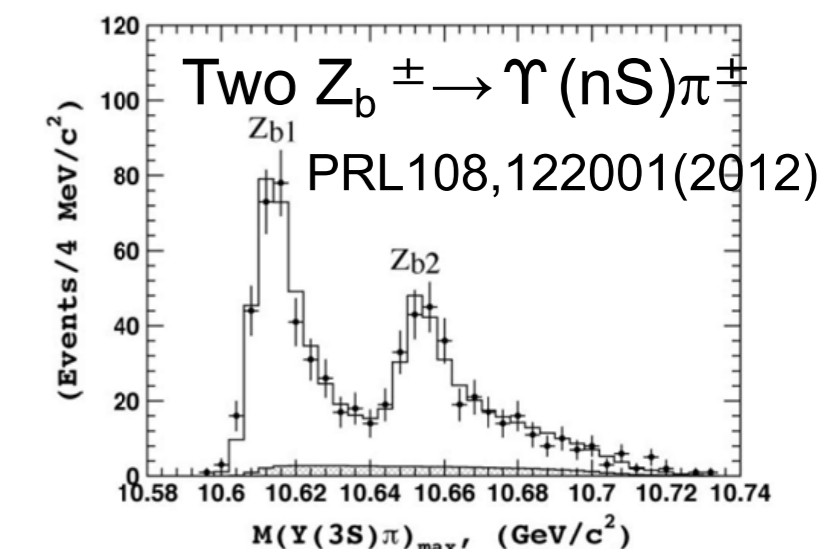
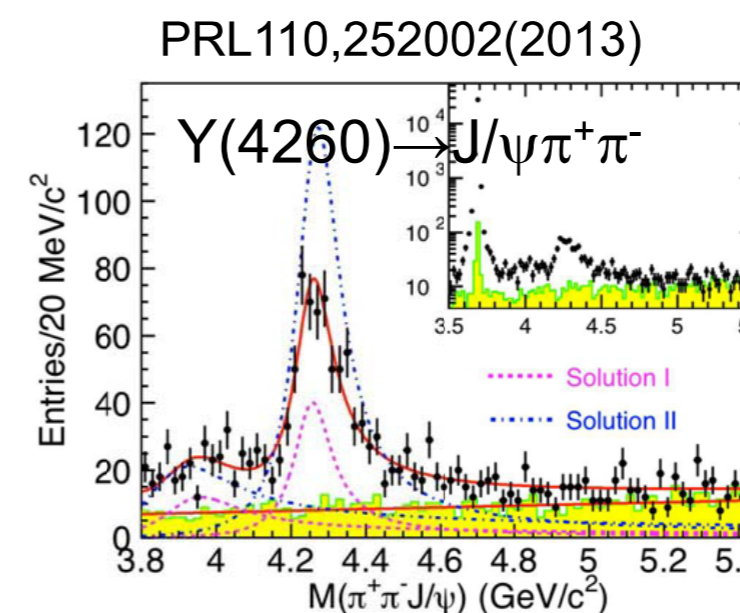
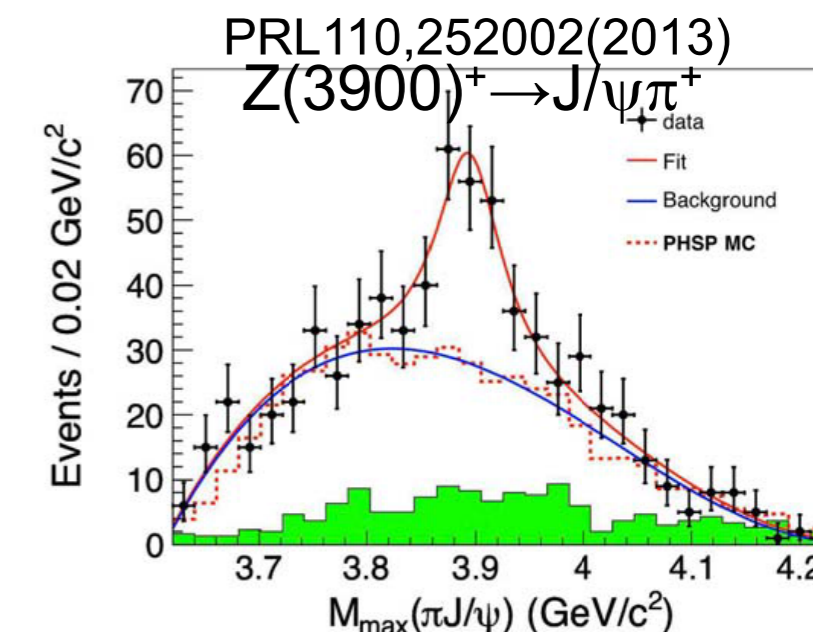
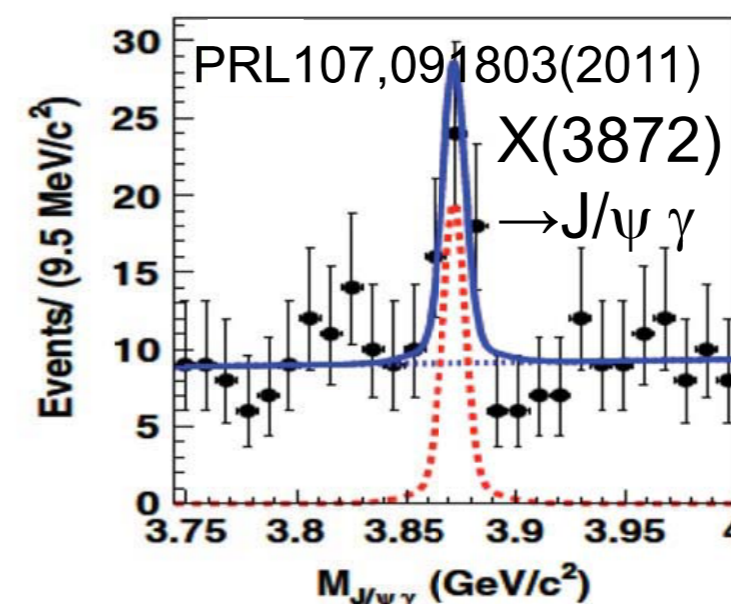
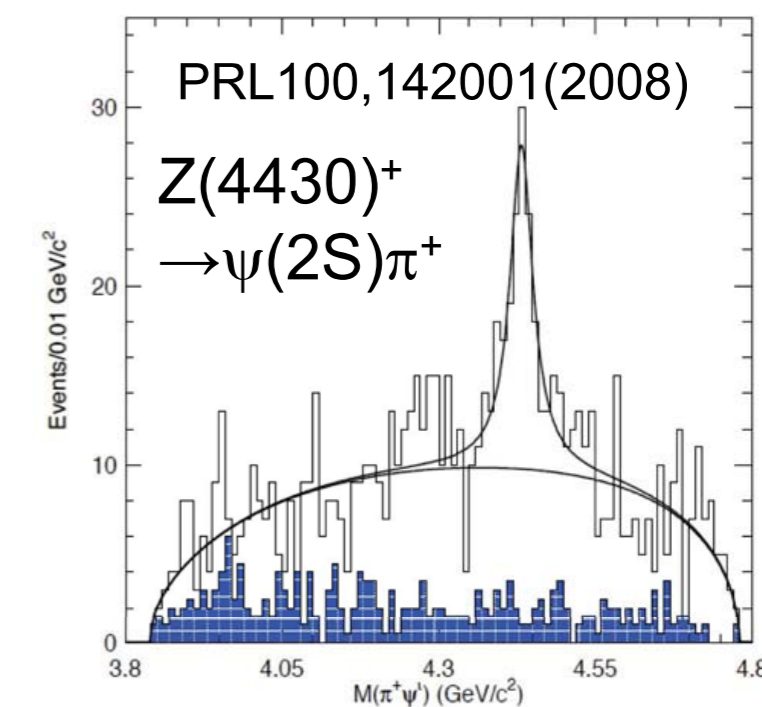
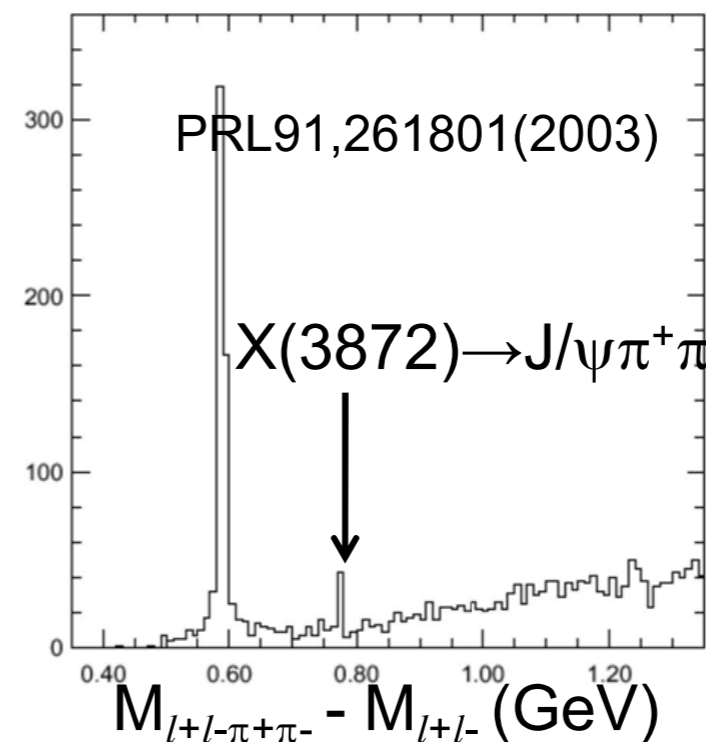

The Belle II Physics Book

Belle-II Collaboration (E. Kou (ed.) (Orsay, LAL) *et al.*) [Show all 534 authors](#)

Aug 30, 2018 - 689 pages

KEK Preprint 2018-27, BELLE2-PUB-PH-2018-001, FERMILAB-PUB-18-398-T, JLAB-THY-18-2780, INT-PUB-18-047, UWThPh 2018-26

e-Print: [arXiv:1808.10567](https://arxiv.org/abs/1808.10567) [hep-ex] | [PDF](#)

Experiment: [KEK-BF-BELLE-II](#)

Abstract (arXiv)

We present the physics program of the Belle II experiment, located on the intensity frontier SuperKEKB e+e- collider. Belle II collected its first collisions in 2018, and is expected to operate for the next decade. It is anticipated to collect 50/ab of collision data over its lifetime. This book is the outcome of a joint effort of Belle II collaborators and theorists through the Belle II theory interface platform (B2TiP), an effort that commenced in 2014. The aim of B2TiP was to elucidate the potential impacts of the Belle II program, which includes a wide scope of physics topics: B physics, charm, tau, quarkonium, electroweak precision measurements and dark sector searches. It is composed of nine working groups (WGs), which are coordinated by teams of theorist and experimentalists conveners: Semileptonic and leptonic B decays, Radiative and Electroweak penguins, phi_1 and phi_2 (time-dependent CP violation) measurements, phi_3 measurements, Charmless hadronic B decay, Charm, Quarkonium(like), tau and low-multiplicity processes, new physics and global fit analyses. This book highlights "golden- and silver-channels", i.e. those that would have the highest potential impact in the field. Theorists scrutinised the role of those measurements and estimated the respective theoretical uncertainties, achievable now as well as prospects for the future. Experimentalists investigated the expected improvements with the large dataset expected from Belle II, taking into account improved performance from the upgraded detector.

14	Quarkonium(like) Physics	431
14.1	Introduction	431
14.2	Heavy Quarkonium: physical picture	432
14.3	Theory Methods	434
14.3.1	Introduction	434
14.3.2	Nonrelativistic Effective Field Theories	434
14.3.3	Lattice	436
14.4	Theory for heavy quarkonium states below open flavour threshold	437
14.4.1	Weakly coupled pNRQCD	437
14.4.2	Strongly coupled pNRQCD	442
14.4.3	Lattice QCD	442
14.4.4	Summary	446
14.5	Theory and theory predictions for quarkonia at and above the open flavour threshold	446
14.5.1	Introduction	446
14.5.2	Observed states	447
14.5.3	Models	452
14.5.4	Lattice QCD	467
14.5.5	Exotics from QCD with EFTs	474
14.5.6	Summary	477
14.6	Belle II prospects for Charmonium(-like) states	477
14.6.1	B decays	477
14.6.2	Initial State Radiation	479
14.6.3	Two Photon Collisions	482
14.6.4	Double Charmonium Production	484
14.6.5	Summary	485
14.7	Belle II prospects for Bottomonium(-like) states	486
14.7.1	Bottomonia below $B\bar{B}$ threshold	486
14.7.2	Dedicated runs above $B\bar{B}$ threshold at Belle II	491
14.8	Early Physics Program at Belle II	495
14.8.1	Potential operating points	496
14.8.2	Operating conditions	496
14.9	Action Items	497
14.10	Conclusions	498

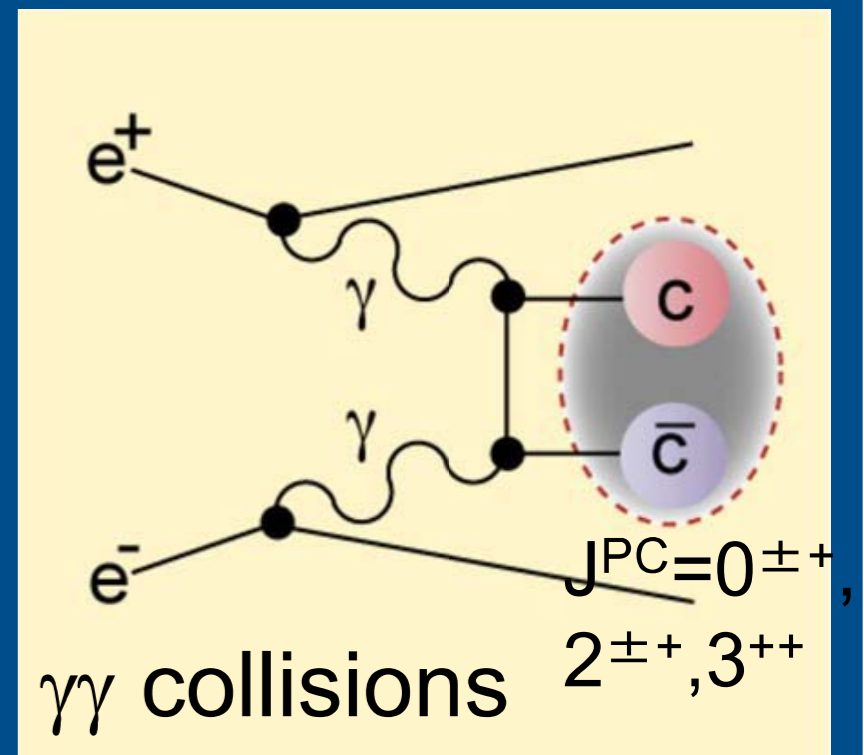
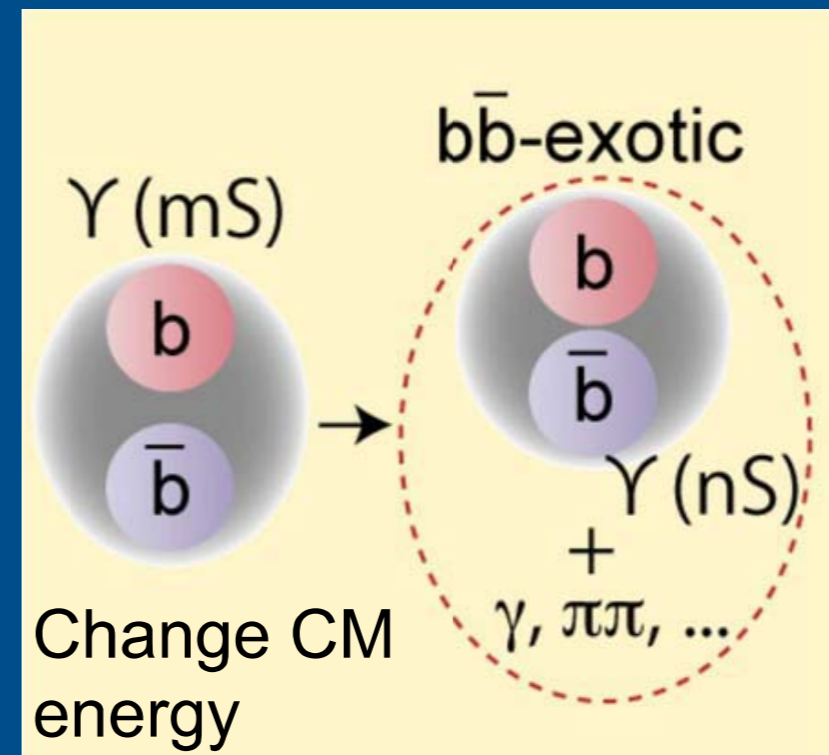
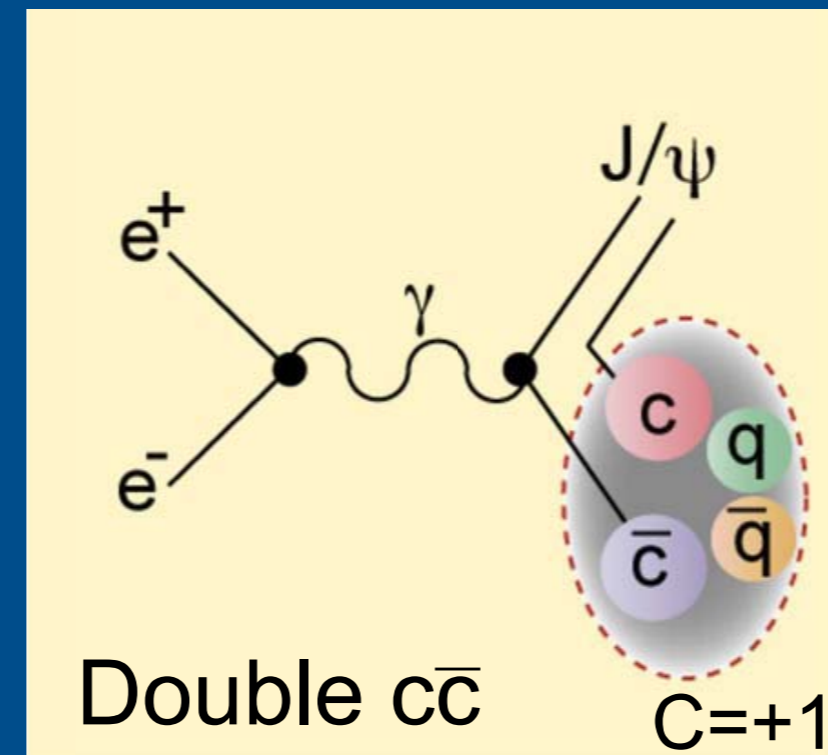
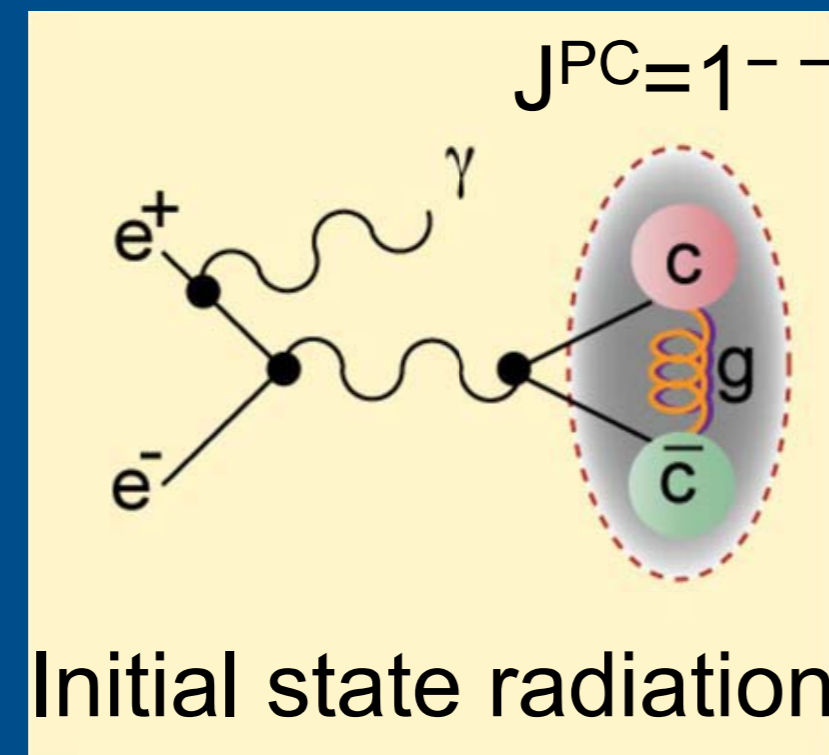
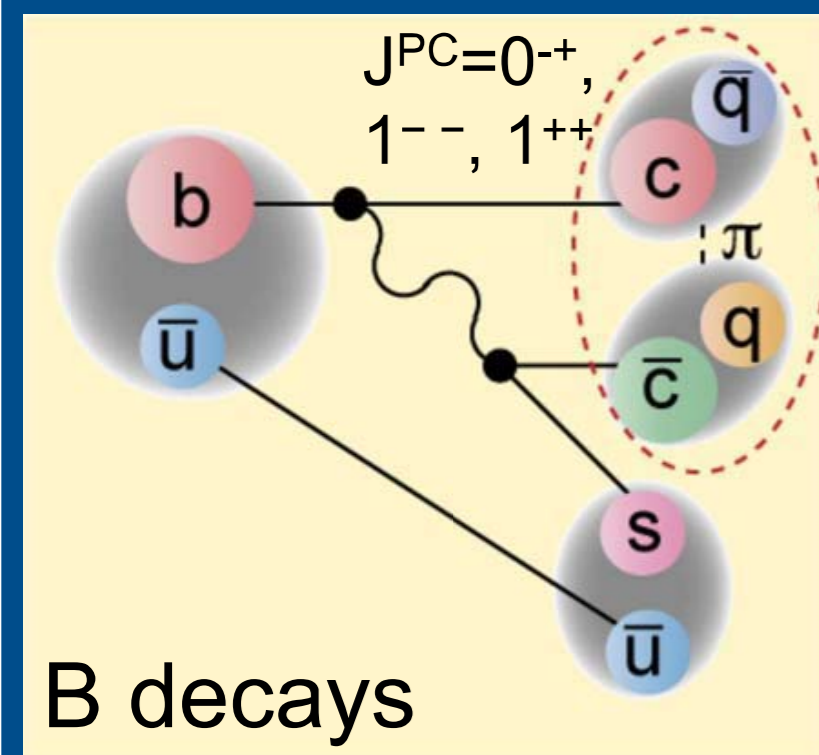

The status of X(3872): the exotic state which started the revolution, most cited Belle publication

PRL.93.072001 (2004)

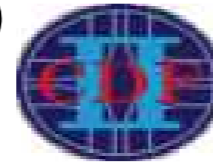
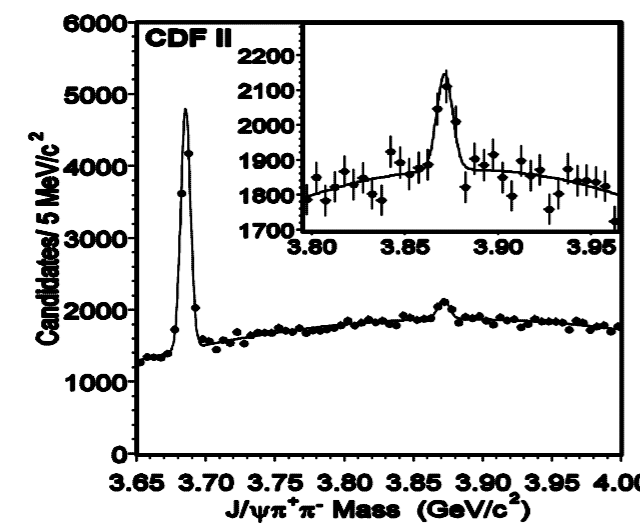

PRL.93.162002 (2004)

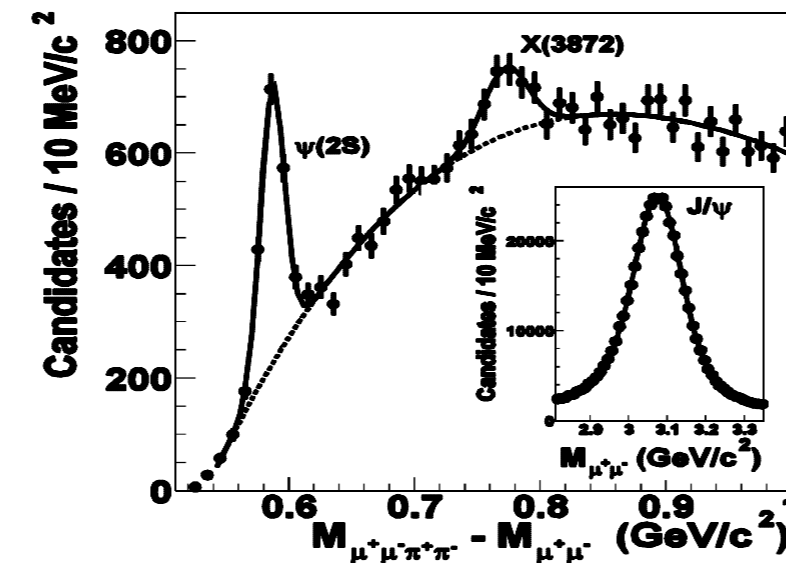

PRD.71.071103 (2005)

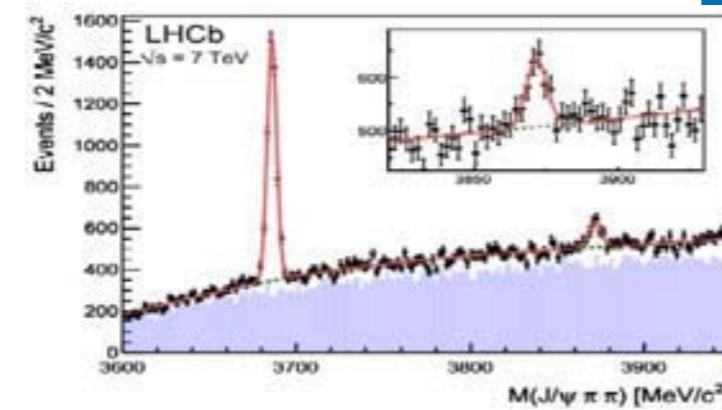
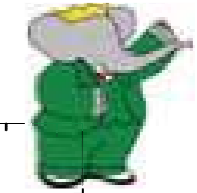
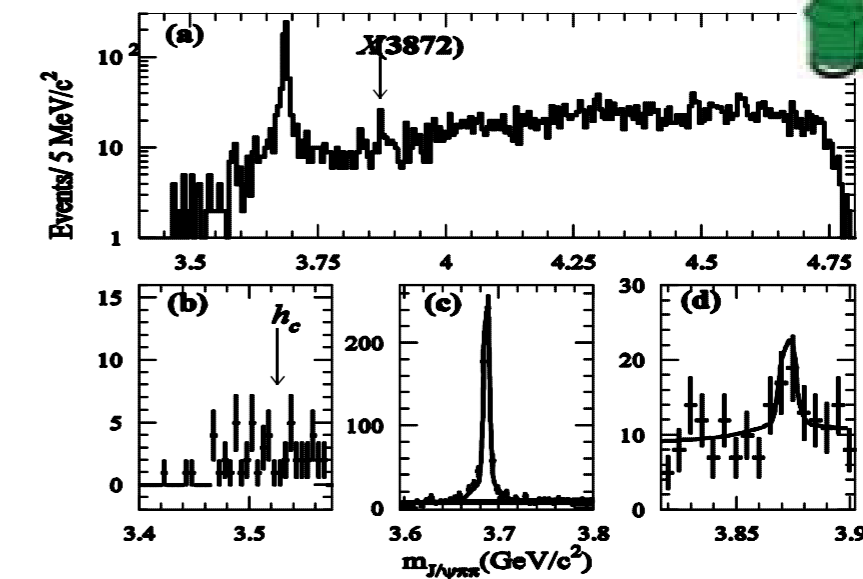

EPJC.72.1972 (2012)

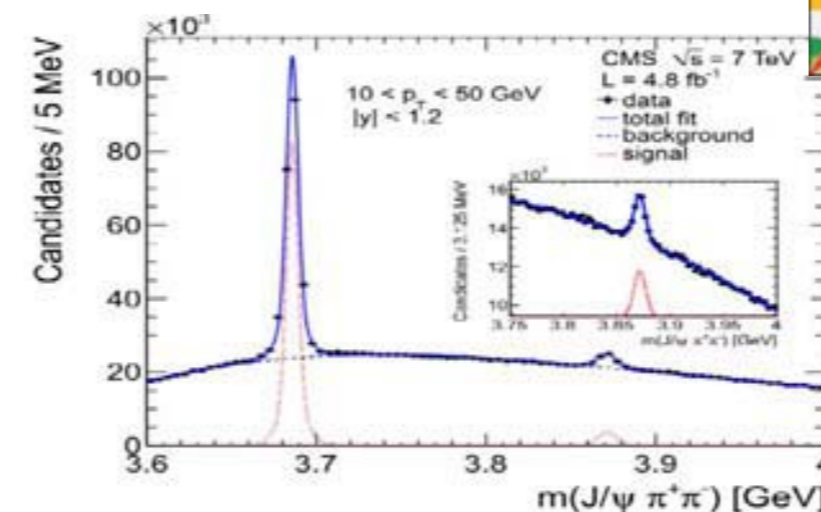

JHEP.04.154 (2013)

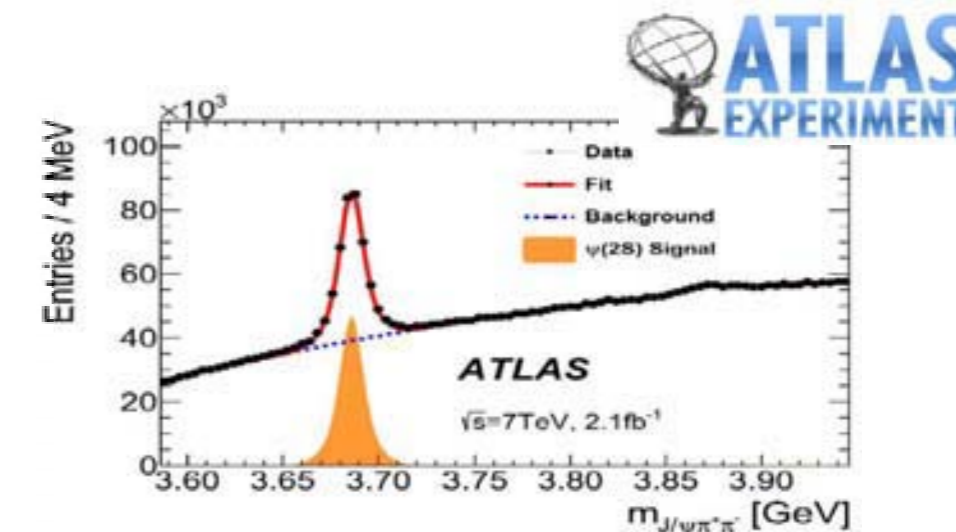

JHEP.79.2014 (2014)

- No quark model prediction in this mass region
- Mass is consistent with DD^* with $O(0.1)$ MeV precision suggesting DD^* molecular state
- Differential cross section for “prompt production” (not from a B meson decay) is measured by LHC, though this **should be suppressed for molecular state!**
- Suggests X(3872) is **superposition of molecular and $c\bar{c}$ state**
- Precise measurements of production and decay processes are essential to understand the exotic nature

The status of X(3872): important details, models, interpretation etc

- ▶ $J^{PC} = 1^{++}$
- ▶ Strong coupling to DD^*
- ▶ No charged or neutral partner observed

▶ Coupled channel, **good description**

▶ PTEP9, 093D01(2013)

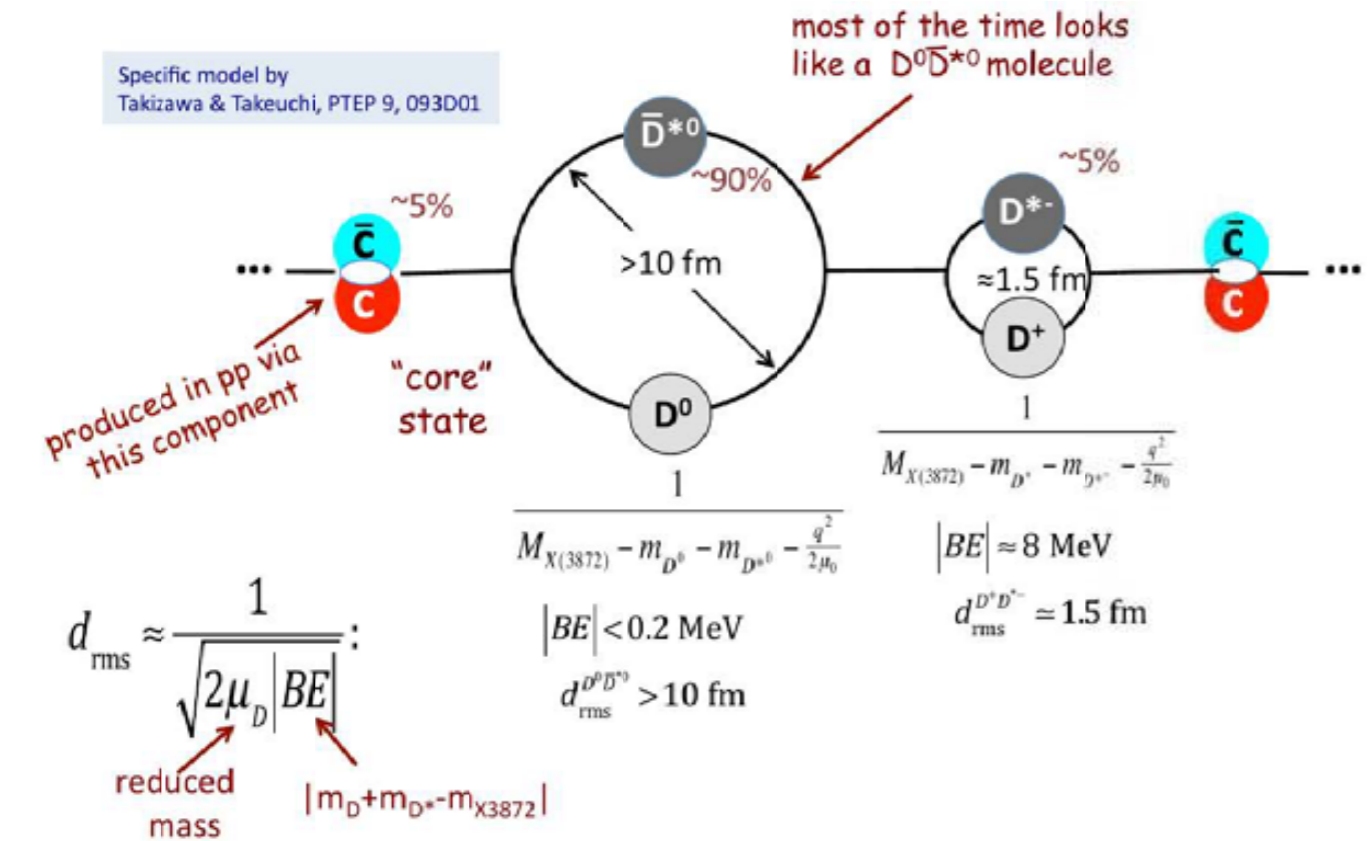

- ▶ Or QCD diquark-diantiquark
 - ▶ Maiani et al., PRD71, 014028(200)
 - ▶ No 1^{++} partner state seen

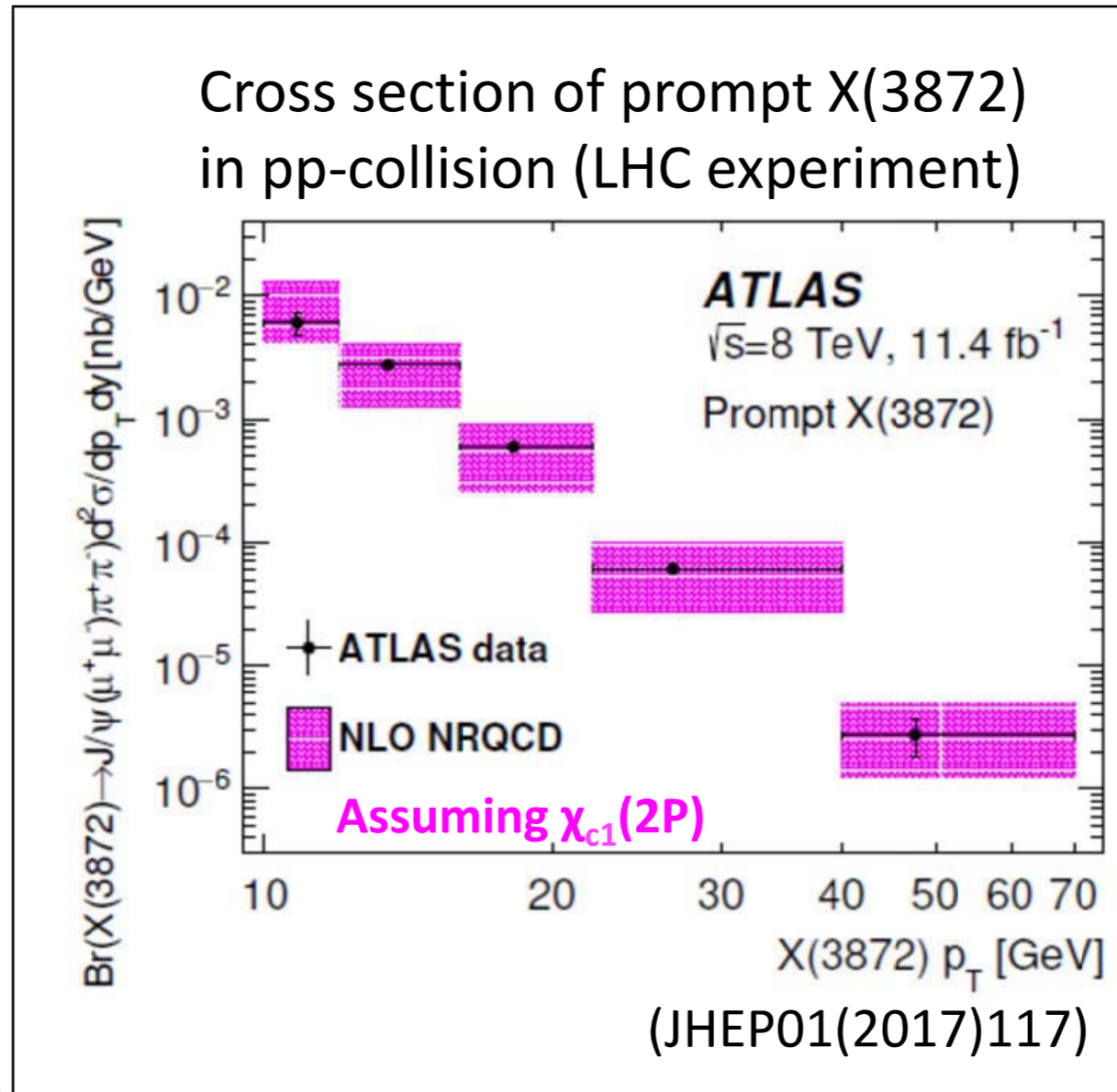
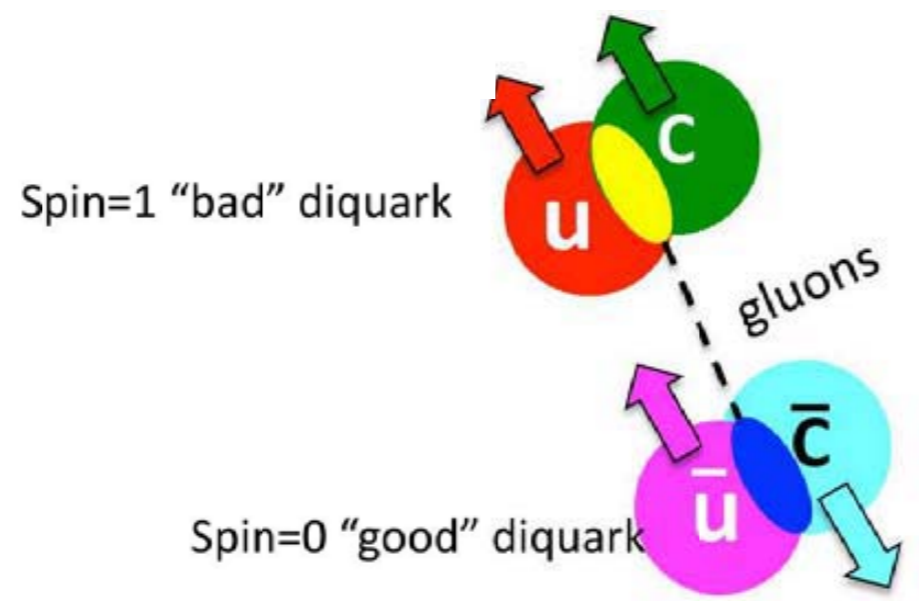

- ▶ Inconsistent with pure molecular interpretation
- Support $DD^* - \chi_{c1}(2P)$ mixture state.
- Need further information about production and decay
- Current X(3872) total width: $\Gamma_{tot} < 1.2 \text{ MeV}$

Want to measure total width (which is related to partial widths):

$$\Gamma(X(3872) \rightarrow f) = \frac{Br(B^\pm \rightarrow K^\pm X(3872)) \times Br(X(3872) \rightarrow f)}{Br(B^\pm \rightarrow K^\pm X(3872))} \times \Gamma_{tot}$$

The status of X(3872): the most enigmatic of all the exotic states, most cited Belle publication

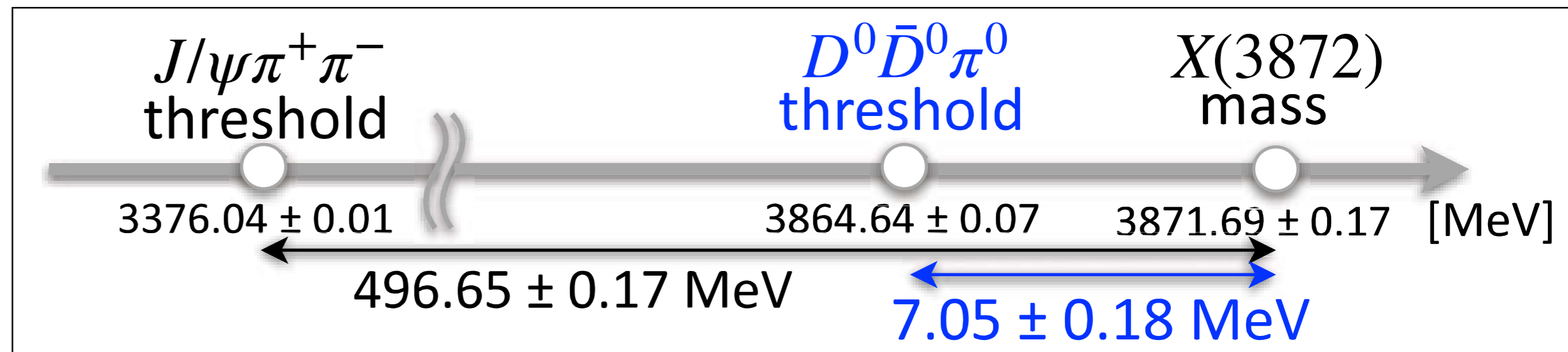
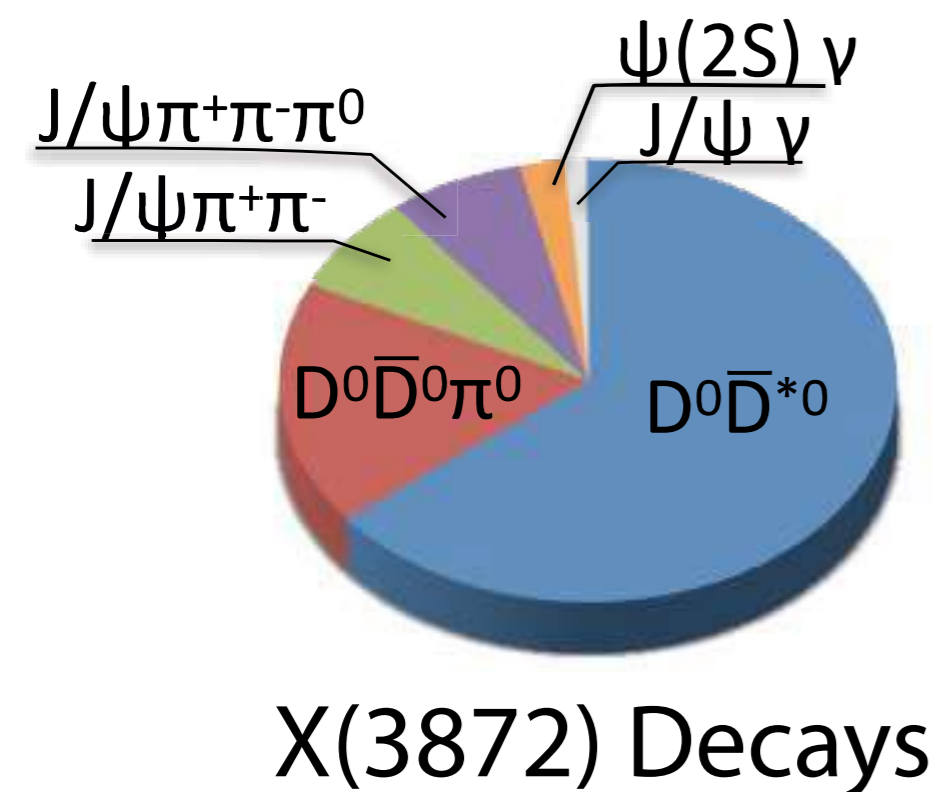

- Previous study (Phys. Rev. D 84, 052004 (2011))
 - Used $X(3872) \rightarrow J/\psi \pi^+ \pi^-$ mode
 - Used a Breit-Wigner (convolved with resolution) fit to mass spectrum

$\Gamma_{\text{tot}} < 1.2 \text{ MeV (90\% C.L.)}$

<

Mass resolution $1.86 \pm 0.01 \text{ MeV}/c^2$

Improvement of mass resolution is essential

- Many decay modes have been observed: $J/\psi \rho$, $J/\psi \omega$, $J/\psi \gamma$, $\psi(2S) \gamma$, DD^* , $DD\pi^0$. etc.
- **Branching fractions** and **decay widths** not known
 - Essential dynamic information!
- Belle II can contribute to a deeper understanding of this state!

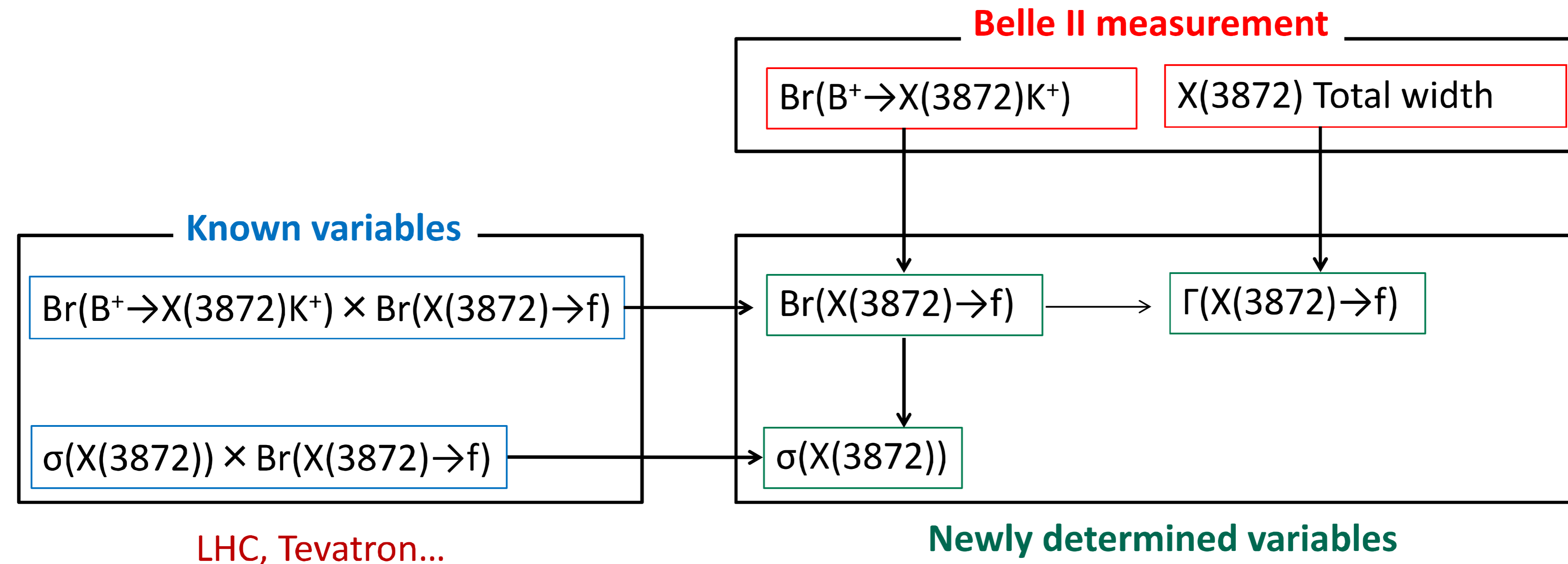

Toward X(3872) Total and Partial Widths Measurements with Belle II

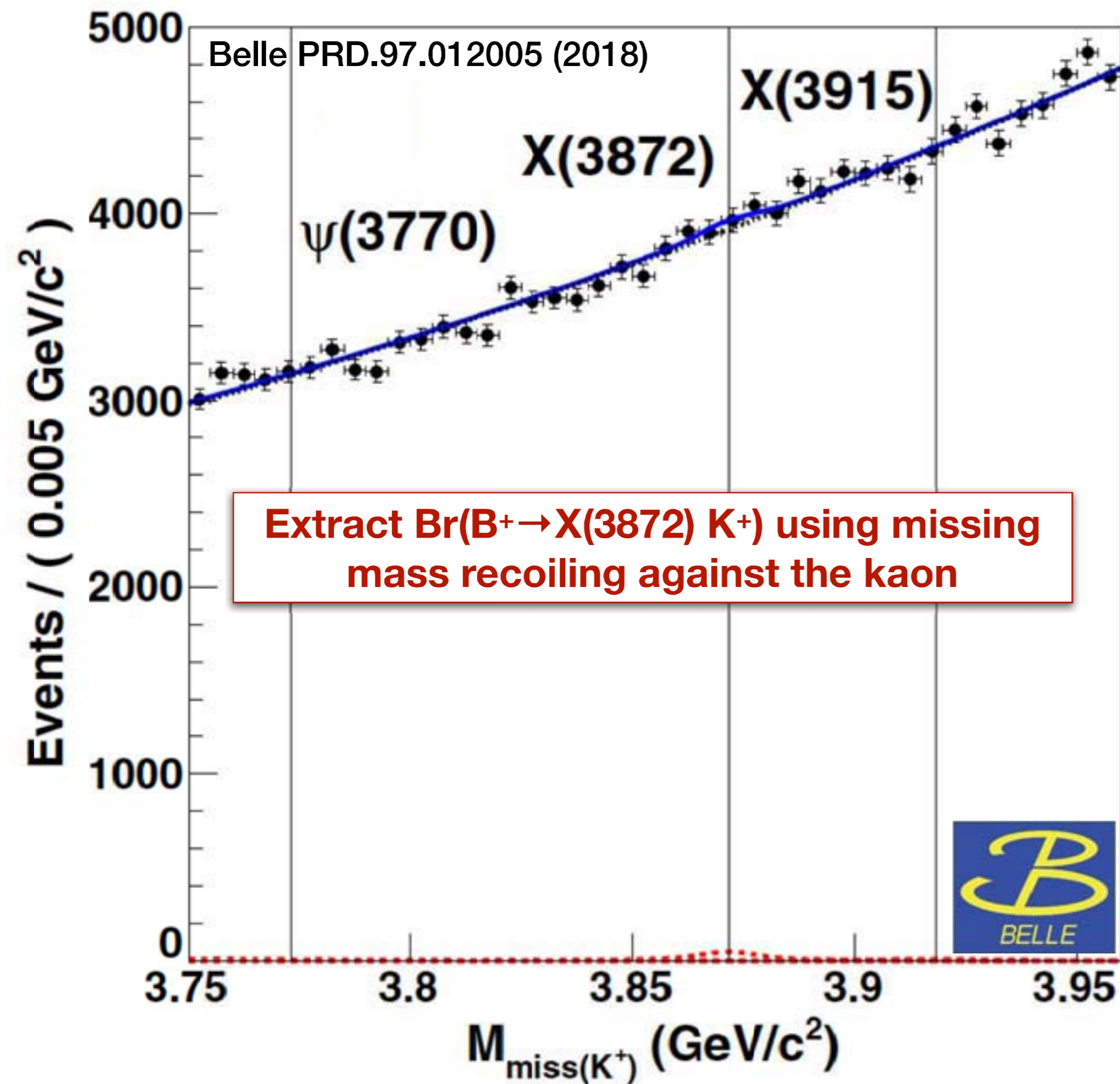

**Mass resolution for $D\bar{D}\pi^0$ is ~ 680 keV:
 ~ 3 times better than $J/\psi\pi^+\pi^-$
 Previously unmeasured due to low statistics**

With the full data sample of Belle II (50 ab⁻¹), total width with values up to
 [90% C.L.] ~ 180 keV
 [3 σ significance] ~ 280 keV
 [5 σ significant] ~ 570 keV can be measured.

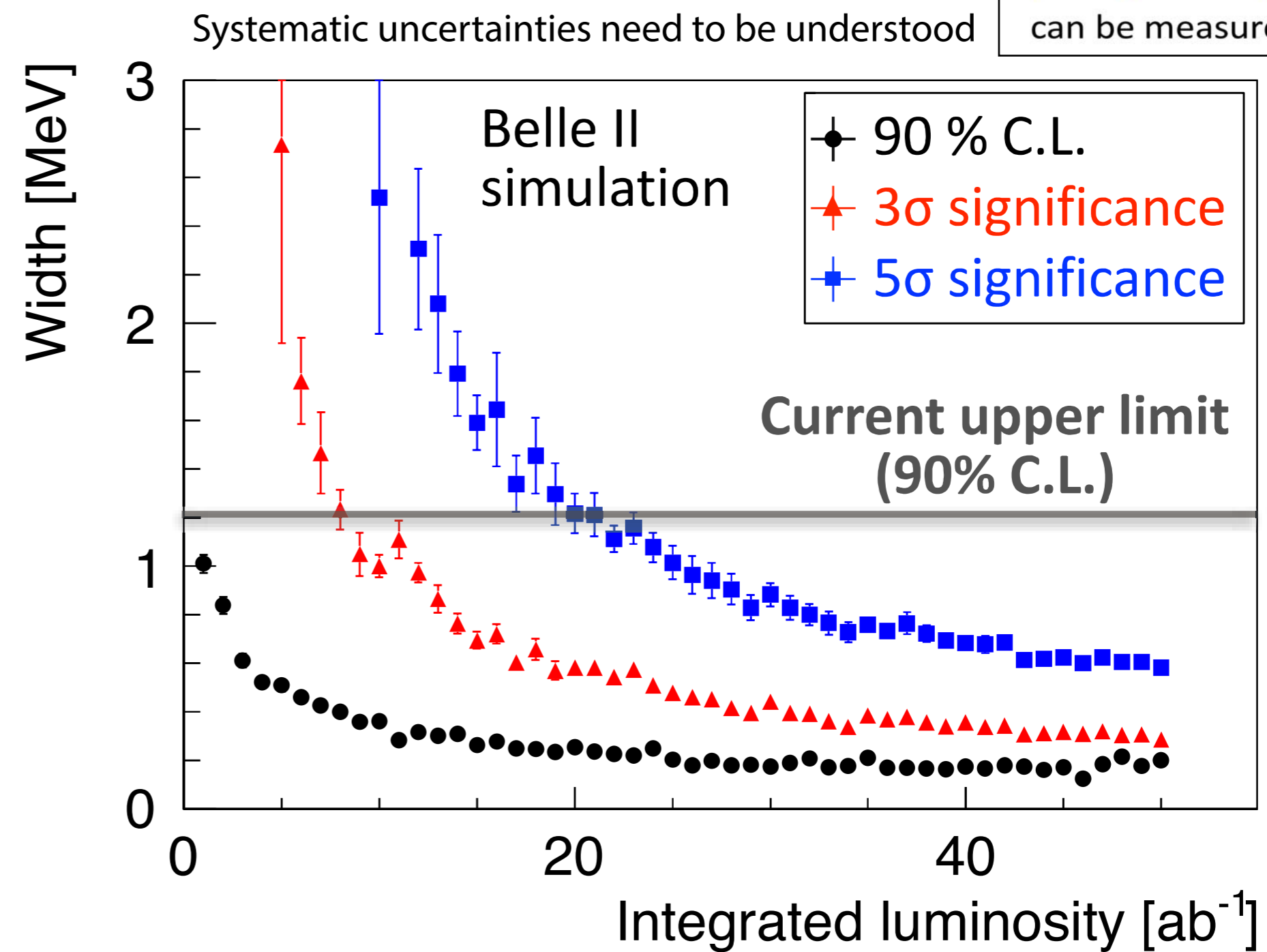

Master thesis of H. Hirata (KMI / Nagoya University)

The status of $Y(4260)$ (and some other “Why?” states)

$Y(4260)$ 4221.1 ± 2.5 47.7 ± 4.0 1^{--} e^+e^- $(\pi^+\pi^- J/\psi)$ BaBar [1191, 1192] (8), 2005 Ok

CLEO [1193, 1194] (11),

Belle [1140, 1195] (15),

BESIII [1139, 1196] (np)

CLEO [1193] (5.1), 2006 Ok

BESIII [1142] (np)

CLEO [1193] (3.7) 2006 NC!

BaBar [1192] (np), 2012 Ok

Belle [1140] (np)

BESIII [1143, 1197] (10) 2013 NC!

BESIII [1147] (np) 2014 NC!

BESIII [1198] (>9) 2014 NC!

BESIII [1129] (6.3) 2013 NC!

BESIII [1139, 1145] (>8), 2013 Ok

Belle [1140] (5.2)

BESIII [1142, 1146] (10.4) 2015 Ok

BESIII [1143, 1147, 1150, 2013 Ok

1151] (>10)

e^+e^- $(\pi^0\pi^0 J/\psi)$

e^+e^- $(K^+K^- J/\psi)$

e^+e^- $(f_0(980)J/\psi)$

e^+e^- $(\pi^+\pi^- h_c)$

e^+e^- $(\pi^0\pi^0 h_c)$

e^+e^- $(\omega\chi_{c0})$

e^+e^- $(\gamma X(3872))$

e^+e^- $(\pi^- Z_c(3900)^+)$

e^+e^- $(\pi^0 Z_c(3900)^0)$

e^+e^- $(\pi^\mp Z_c(4020)^{\pm,0})$

State	M , MeV	Γ , MeV	J^{PC}	Process (mode)	Experiment (# σ)	Year	Status
$X(4274)$	$4273.3^{+19.1}_{-9.0}$	$56.2^{+13.8}_{-15.6}$	1^{++}	$B^+ K^+(\phi J/\psi)$	CDF [1180] (3.1), LHCb [1182] (1.0), CMS [1183] (>3), D0 [1184] (np), LHCb [1186, 1187] (6.0)	2011	NC!
or $Y(4274)$							
$X(4350)$	$4350.6^{+4.6}_{-5.1}$	13^{+18}_{-10}	$0/2^{?+}$	$e^+e^- e^+e^-(\phi J/\psi)$	Belle [1199] (3.2)	2009	NC!
$Y(4360)$	4341.2 ± 5.4	101.9 ± 9.3	1^{--}	$e^+e^- (\pi^+\pi^-\psi(2S))$	Belle [1148, 1200] (8), BaBar [1201] (np)	2007	Ok
				$e^+e^- (\pi^+\pi^- J/\psi)$	BESIII [1196] (7.6)	2016	NC!
				$e^+e^- (\pi^+\pi^-\psi_2(3823))$	BESIII [1165] (np)	2015	NC!
				$e^+e^- (\pi^0 Z_c(3900)^0)$	BESIII [1142] (np)	2015	NC!
				$e^+e^- (\pi^- Z_c(4020)^+)$	Belle [1148] (3.5), BESIII [1149] (9.2)	2014	NC!
$Y(4390)$	4391.6 ± 6.4	139.5 ± 16.1	1^{--}	$e^+e^- (\pi^+\pi^- h_c)$	BESIII [1197] (10)	2016	NC!
				$e^+e^- (\pi^\mp Z_c(4020)^{\pm,0})$	BESIII [1143, 1147] (np)	2013	NC!
$\psi(4415)$	4421 ± 4	62 ± 20	1^{--}	e^+e^- (hadrons)	PDG [70]	1976	Ok
				$e^+e^- (\eta J/\psi)$	Belle [1176] (np), BESIII [1189] (>5)	2013	NC!
				$e^+e^- (\omega\chi_{c2})$	BESIII [1202] (10.4)	2015	NC!
				$e^+e^- (D\bar{D}_2^*(2460))$	Belle [1203] (10)	2007	NC!
$Z(4430)^+$	4478^{+15}_{-18}	181 ± 31	1^{+-}	$\bar{B}^0 K^-(\pi^+\psi(2S))$	Belle [1204-1206] (6.4), BaBar [1207] (2.4), LHCb [1208, 1209] (13.9)	2007	Ok
				$\bar{B}^0 K^-(\pi^+ J/\psi)$	Belle [1190] (4.0)	2014	NC!
$X(4500)$	4506^{+16}_{-19}	92^{+30}_{-29}	0^{++}	$B^+ K^+(\phi J/\psi)$	LHCb [1186, 1187] (6.1)	2016	NC!
$Y(4660)$	4643 ± 9	72 ± 11	1^{--}	$e^+e^- (\pi^+\pi^-\psi(2S))$	Belle [1148, 1200] (5.8), BaBar [1201] (5)	2007	Ok
				$e^+e^- (A_1^+ \bar{A}_1^-)$	Belle [1210] (8.2)	2007	NC!
$X(4700)$	4704^{+17}_{-26}	120^{+52}_{-45}	0^{++}	$B^+ K^+(\phi J/\psi)$	LHCb [1186, 1187] (5.6)	2016	NC!
$\Upsilon(4S)$	10579.4 ± 1.2	20.5 ± 2.5	1^{--}	e^+e^- (hadrons)	PDG [70]	1985	Ok
				$e^+e^- (\pi^+\pi^- \Upsilon(1S, 2S))$	BaBar [1211, 1212] (>10), Belle [1213, 1214] (11.2)	2006	Ok
				$e^+e^- (\eta \Upsilon(1S))$	BaBar [1212] (>11)	2008	Ok
				$e^+e^- (\eta h_b(1P))$	Belle [1092] (11)	2015	Ok
$\Upsilon(10860)$	10891 ± 4	54 ± 7	1^{--}	e^+e^- (hadrons)	PDG [70]	1985	Ok
				$e^+e^- (\pi^+\pi^- \Upsilon(1S, 2S, 3S))$	Belle [1153, 1154, 1215] (>10)	2007	Ok
				$e^+e^- (\pi^0\pi^0 \Upsilon(1S, 2S, 3S))$	Belle [1155] (np)	2013	Ok
				$e^+e^- (f_0(980) \Upsilon(1S))$	Belle [1153-1155] (>8)	2011	Ok
				$e^+e^- (f_2(1275) \Upsilon(1S))$	Belle [1153-1155] (np)	2011	NC!
				$e^+e^- (\eta \Upsilon(1S, 2S))$	Belle (10)	2012	NC!
				$e^+e^- (K^+K^- \Upsilon(1S))$	Belle [1215] (4.9)	2007	NC!
				$e^+e^- (\omega \chi_{b1,2}(1P))$	Belle [1216] (12)	2014	Ok
				$e^+e^- ((\pi^+\pi^-\pi^0)_{\text{non-}\omega} \chi_{b1,2}(1P))$	Belle [1216] (4.9)	2014	NC!
				$e^+e^- (\pi^+\pi^- \Upsilon_J(1D))$	Belle (9)	2012	NC!
				$e^+e^- (\eta \Upsilon_J(1D))$	Belle (np)	2014	NC!
				$e^+e^- (\pi Z_b(10610, 10650))$	Belle [1153, 1155] (>10)	2011	Ok
				$e^+e^- (B_s^* \bar{B}_s^*)$	Belle [1217] (np)	2016	NC!
$\Upsilon(11020)$	$10987.5^{+11.0}_{-3.4}$	61^{+9}_{-28}	1^{--}	e^+e^- (hadrons)	PDG [70]	1985	Ok
				$e^+e^- (\pi^+\pi^- \Upsilon(1S, 2S, 3S))$	Belle [1218] (np)	2015	NC!
				$e^+e^- (\pi^\mp Z_b(10610, 10650)^\pm)$	Belle [1158] (5.3)	2015	NC!

Many other XYZ states will also be investigated at Belle II

The Belle II Physics Book, arXiv:1808.10567 [hep-ex]

The status of Y(4260) (and some other "Why?" states)

Y(4260):

Why such state(s)?

And what is it / are they?

Charmonium?

Four-quark state?

Molecule?

A superposition of all of these?

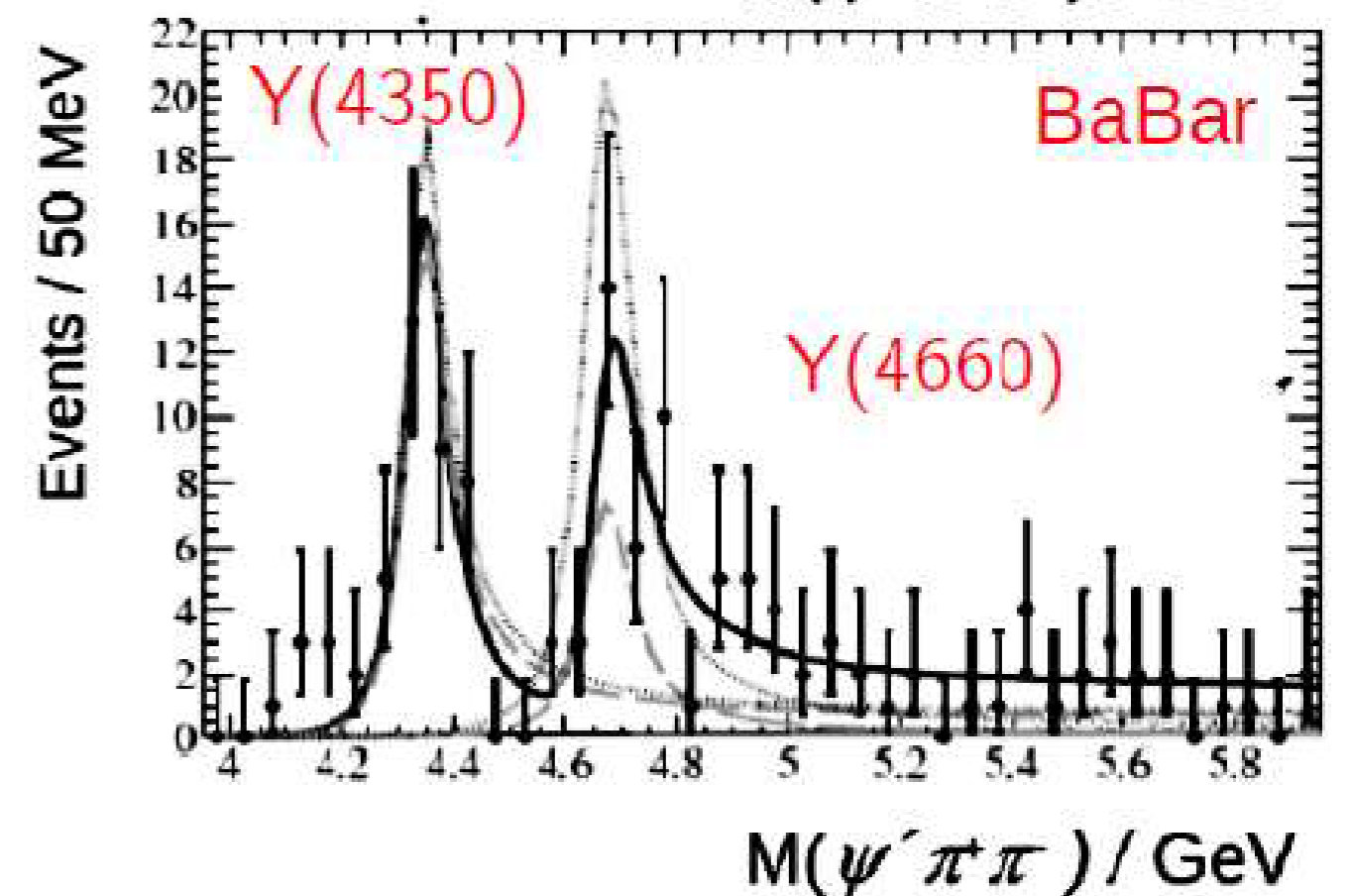
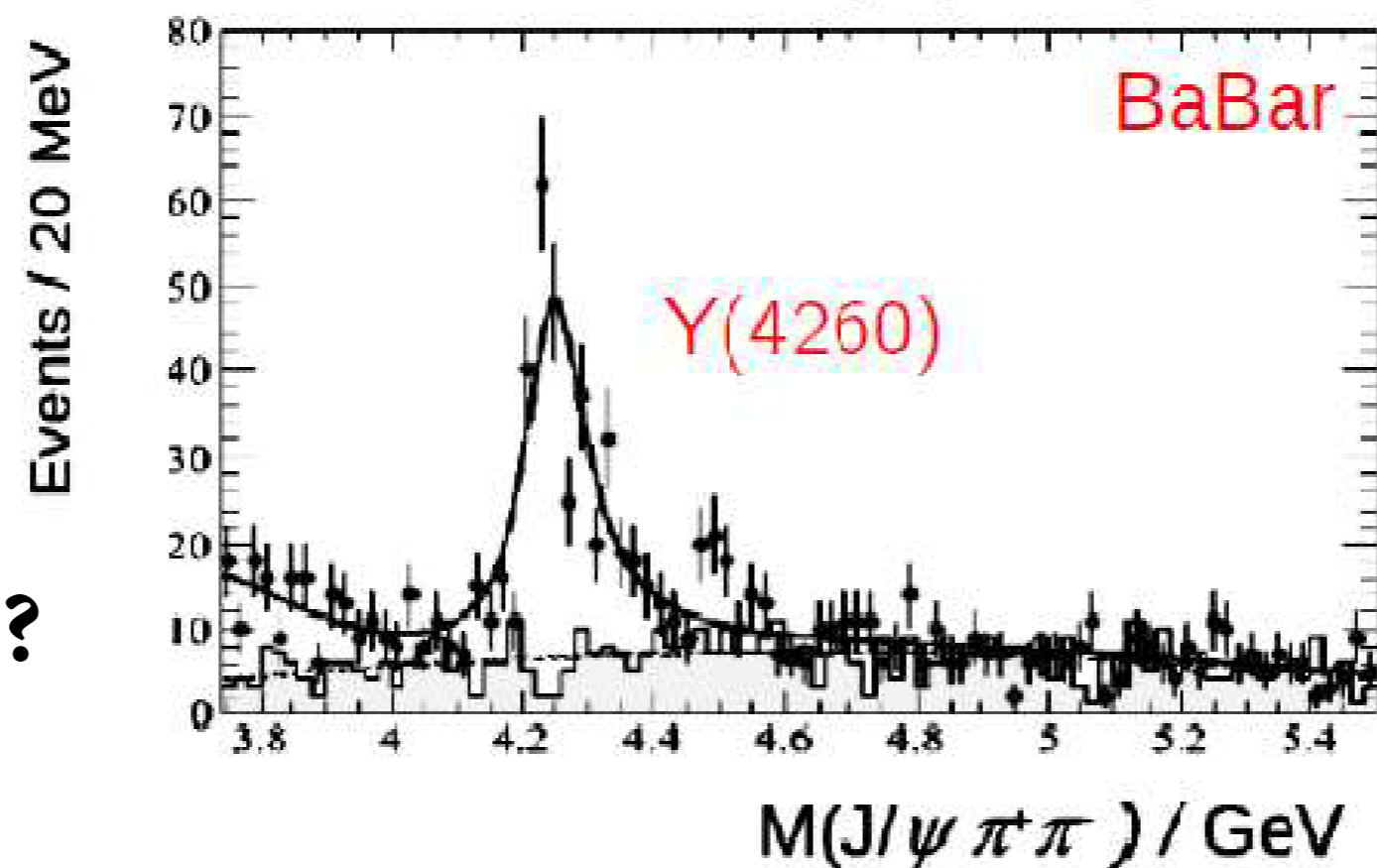
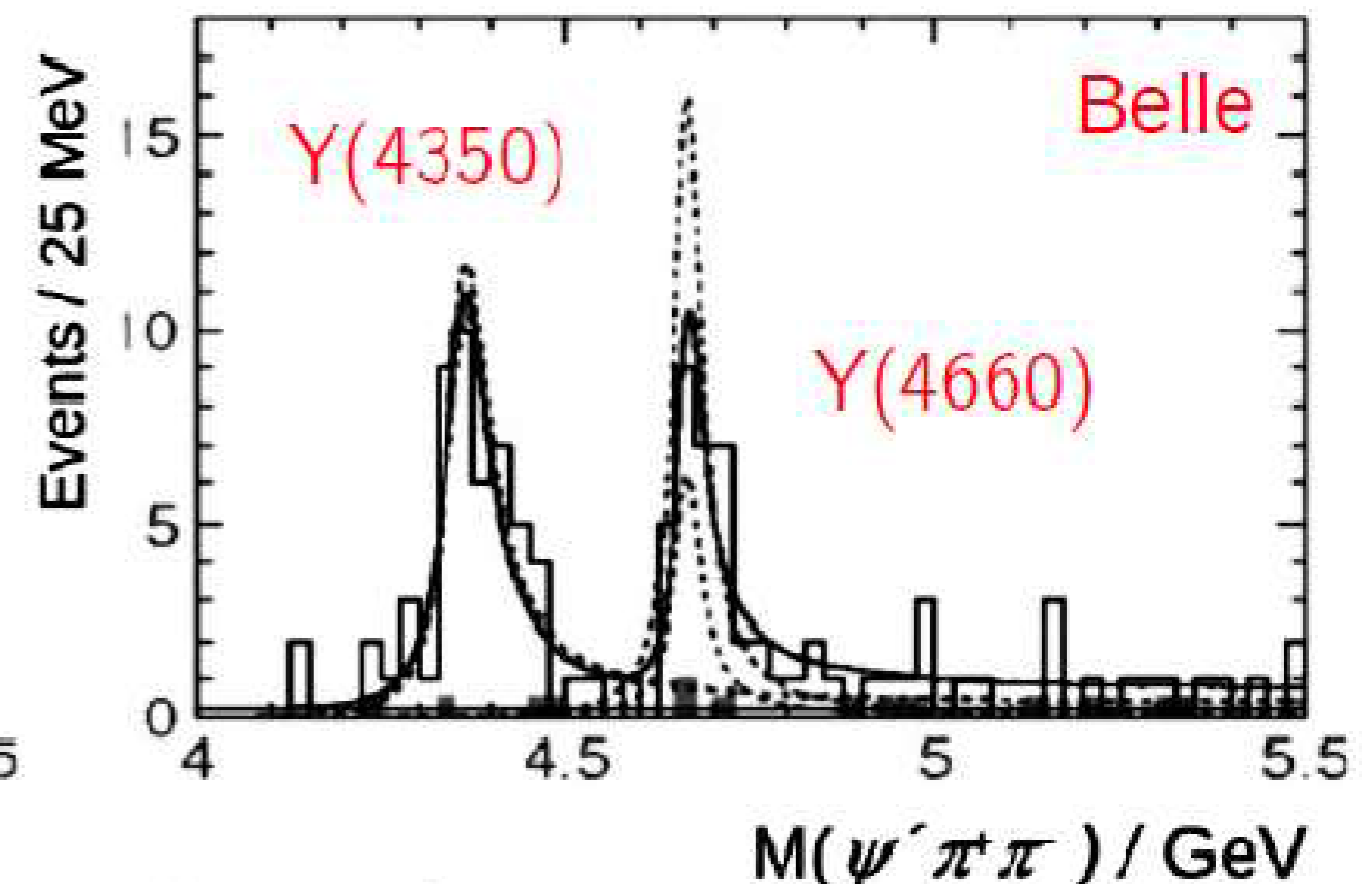
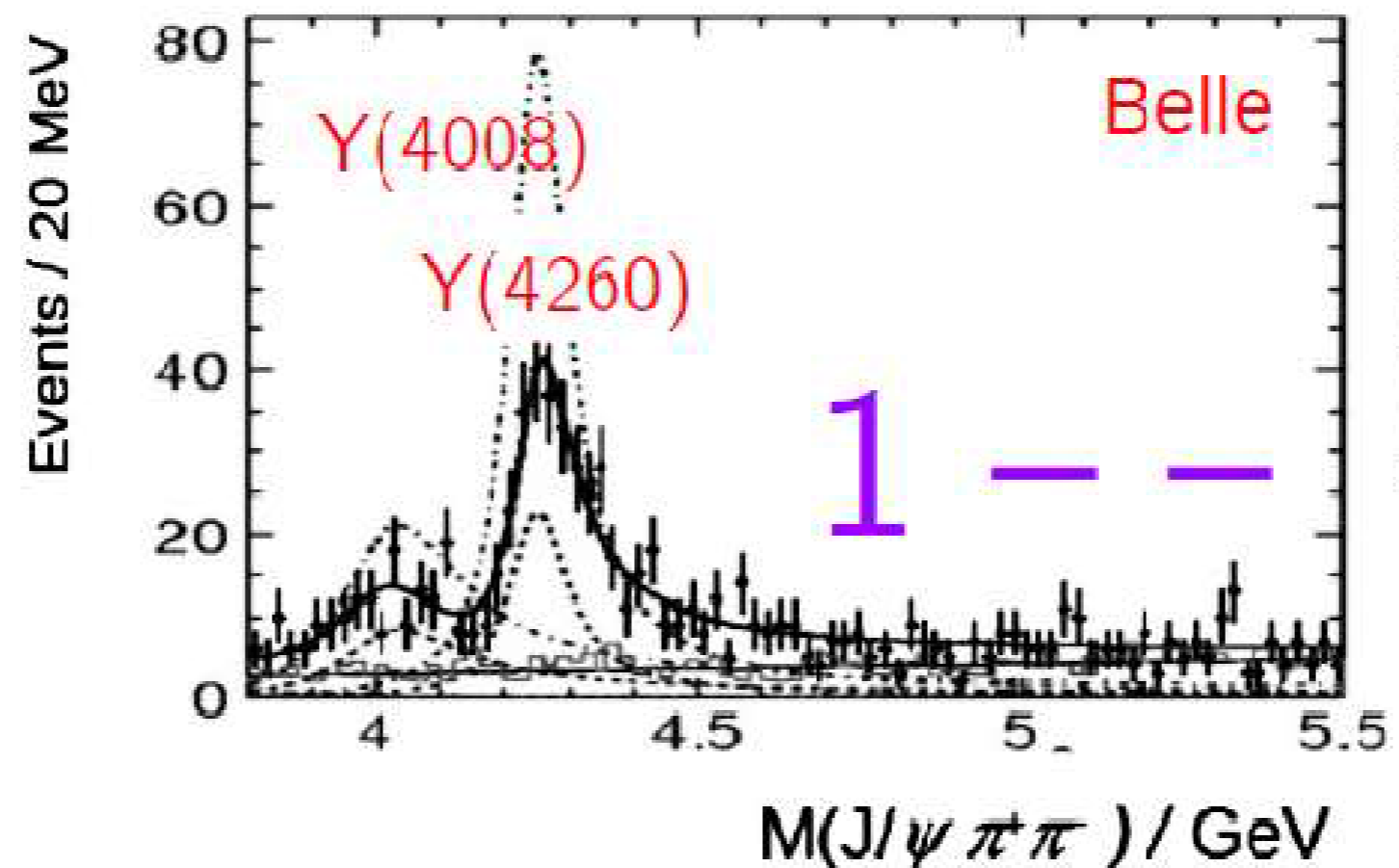

Enigmatic Y(4260) (discovered by BaBar in ISR, searched for in B decays)

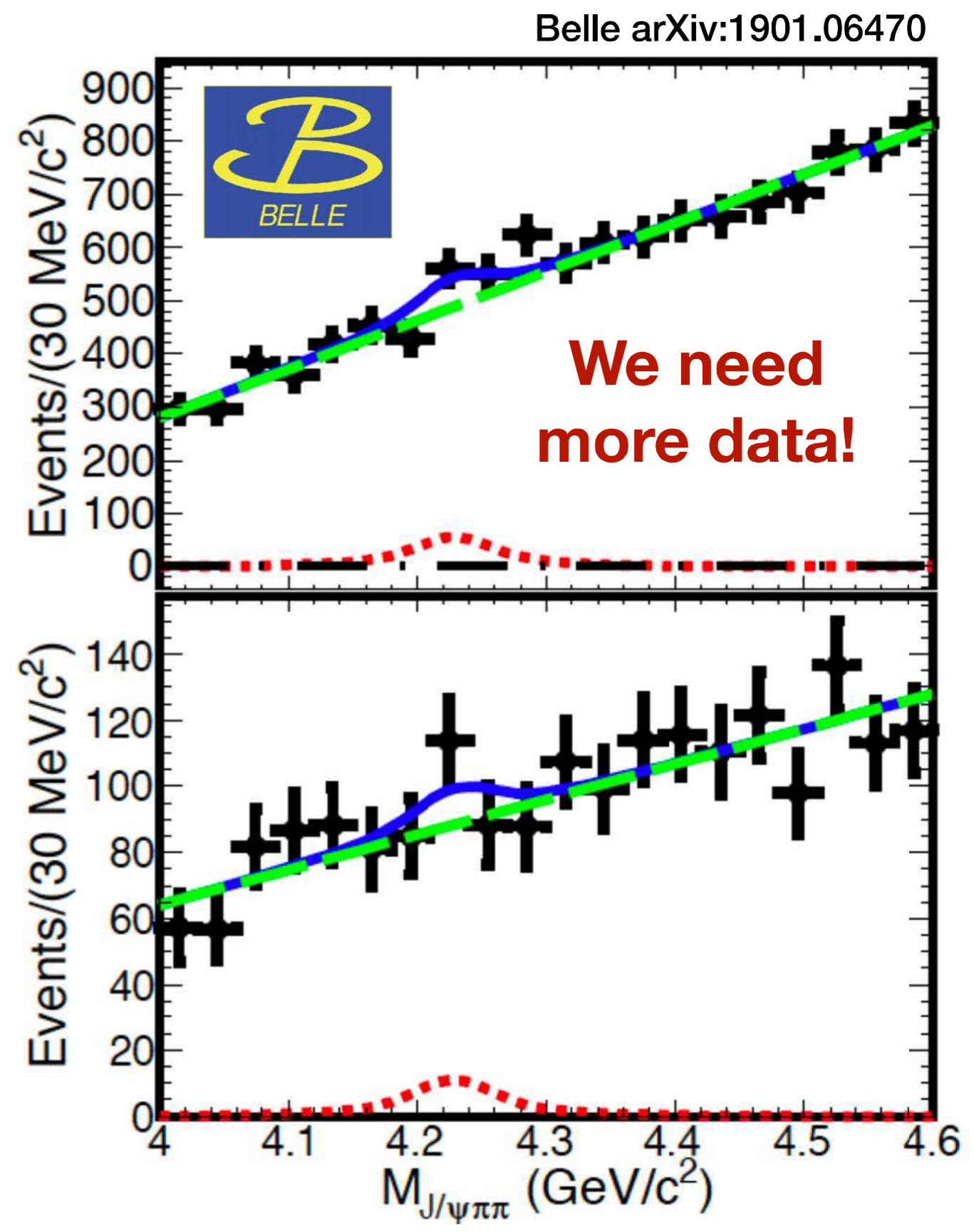
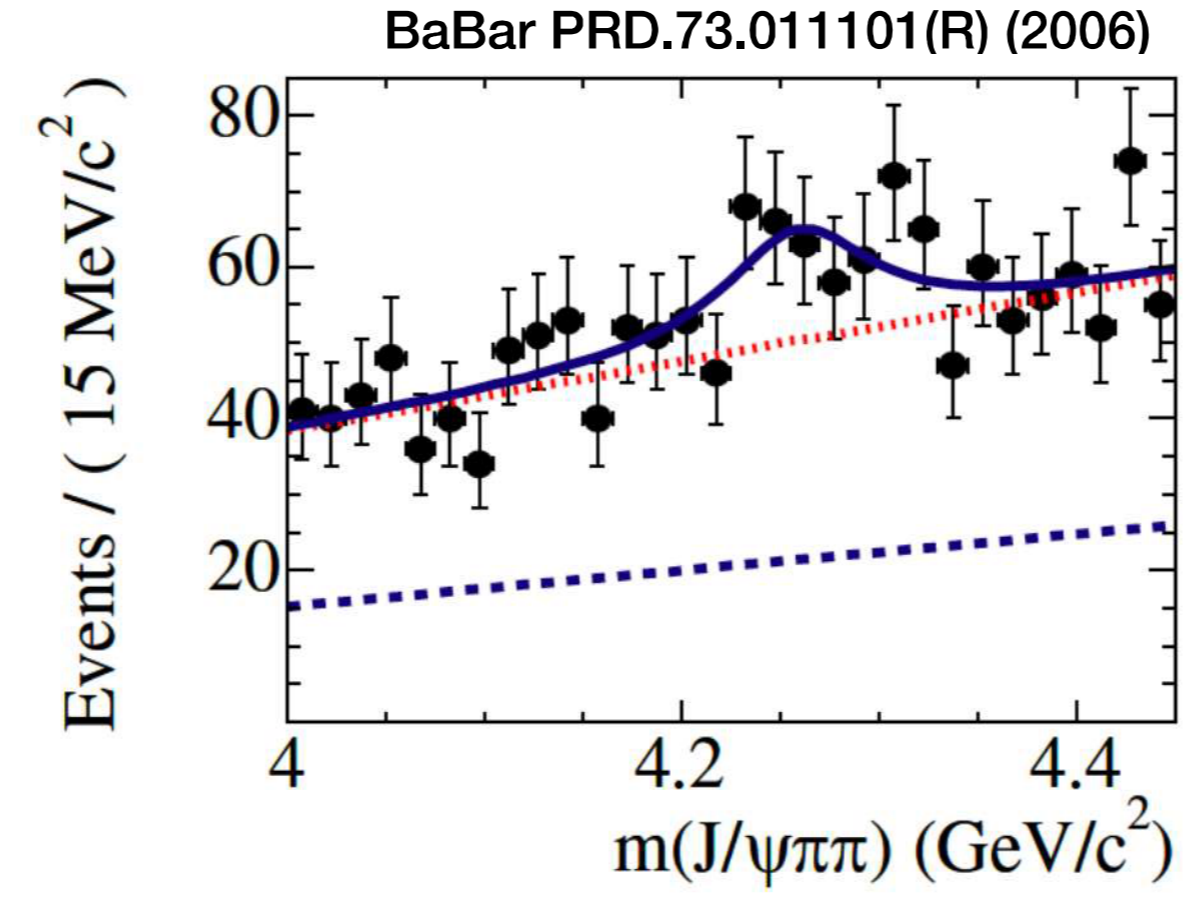
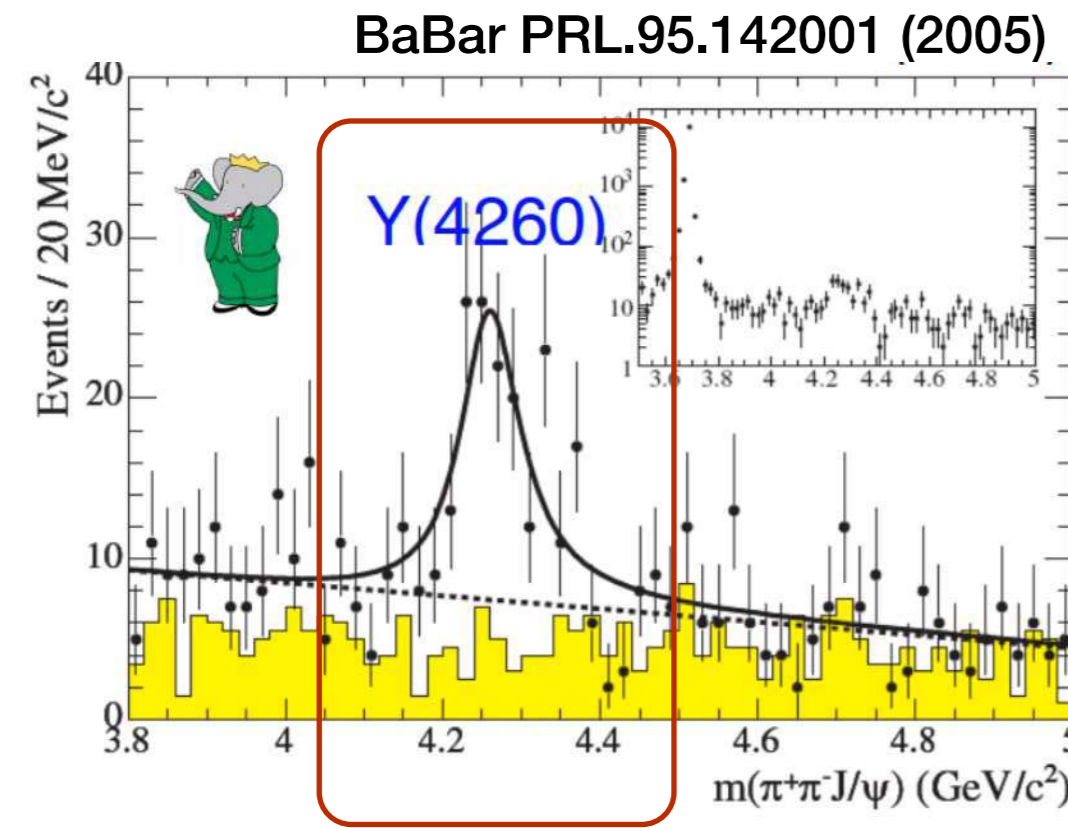

How many states?

$$\mathcal{B}(B^- \rightarrow Y(4260)K^-), Y(4260) \rightarrow J/\psi\pi^+\pi^- < 2.9 \times 10^{-5}$$

- Y(4260) discovered in $e^+e^- \rightarrow \gamma_{\text{ISR}}\pi^+\pi^-J/\psi$
 - Overpopulation of charmonium states!
 - Molecular ($D_1\bar{D}$), hybrid, tetraquark all offer viable descriptions
- Some predictions (e.g. mixed-state model based upon QCD sum rules), suggest $B^+ \rightarrow Y(4260)K^+$ with $Y(4260) \rightarrow \pi^+\pi^-J/\psi$ may have a branching fraction in the range $3.0 \times 10^{-8} - 1.8 \times 10^{-6}$

Improved by factor of 2

$$\mathcal{B}(B^+ \rightarrow Y(4260)K^+) \times \mathcal{B}(Y(4260) \rightarrow J/\psi\pi^+\pi^-) < 1.4 \times 10^{-5}$$

$$\mathcal{B}(B^0 \rightarrow Y(4260)K^0) \times \mathcal{B}(Y(4260) \rightarrow J/\psi\pi^+\pi^-) < 1.7 \times 10^{-5}$$

New upper limit

Belle discovered some of the expected quarkonium states and (somewhat) unexpected exotic states / resonances / ?

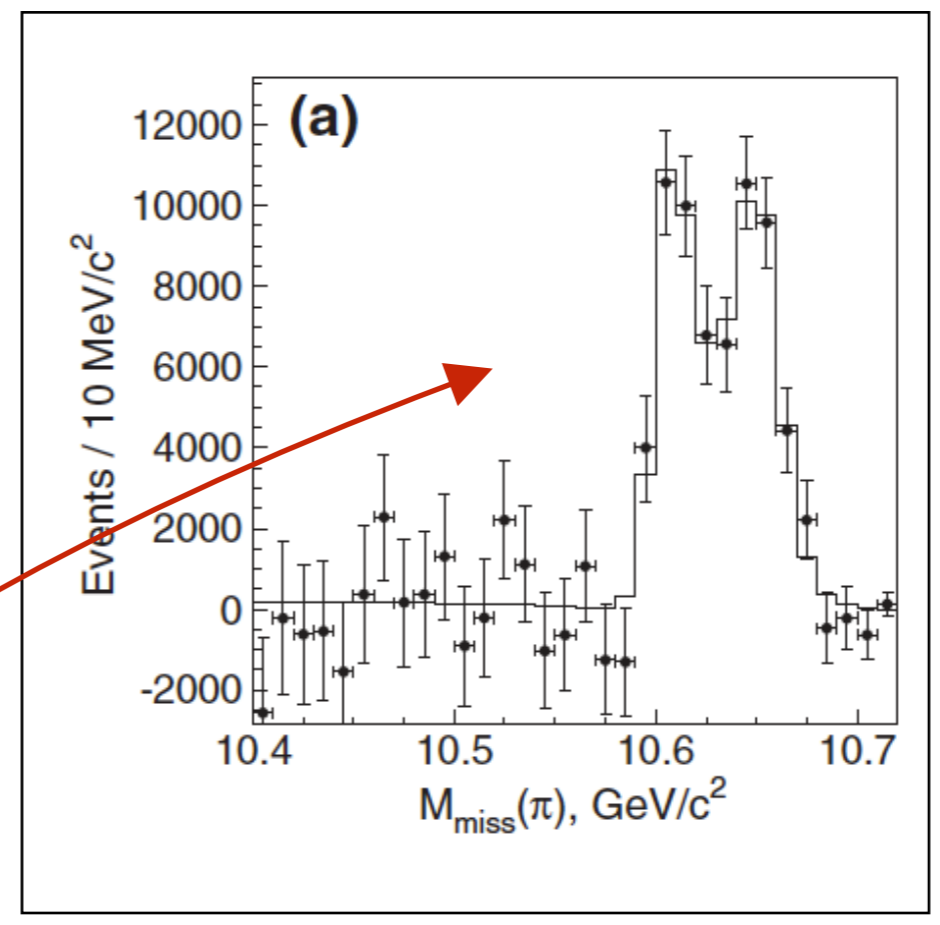

$h_b(1P) \pi^+\pi^-$
 $Z_b(10610)$ and $Z_b(10650)$
PRL 108, 122001 (2012)

First Observation of the P -Wave Spin-Singlet Bottomonium States $h_b(1P)$ and $h_b(2P)$

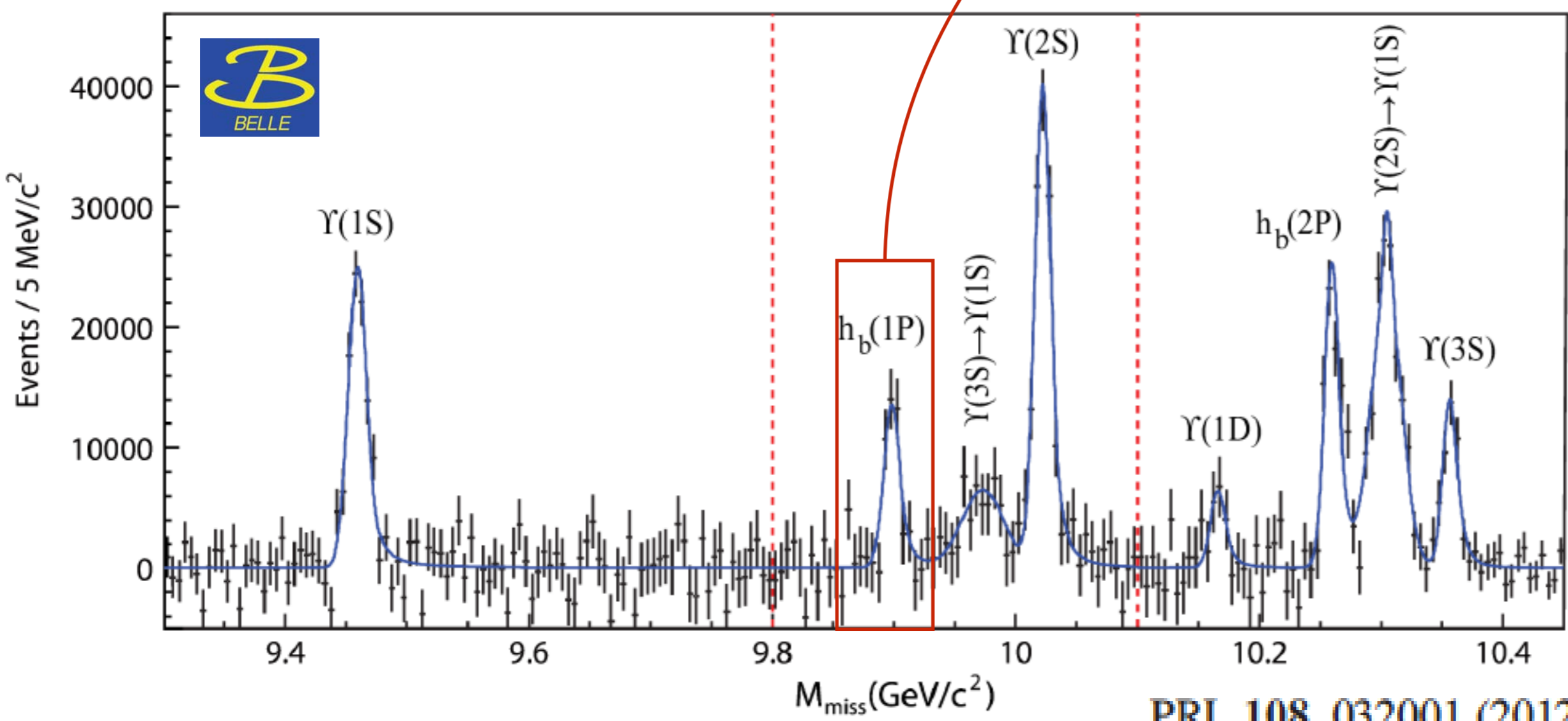

PRL 108, 032001 (2012)

Bottomonium-like states: Physics case for energy scan above the $B\bar{B}$ threshold at Belle-II

A. E. Bondar, R. V. Mizuk & M. B. Voloshin

Modern Physics Letters A
 Vol. 32, No. 4 (2017) 1750025 (18 pages)
 © World Scientific Publishing Company
 DOI: 10.1142/S0217732317500250

Table 5. Expected molecular states with the structure $B\bar{B}$, $B\bar{B}^*$ and $B^*\bar{B}^*$.

$I^G(J^P)$	Name	Composition	Co-produced particles (Threshold, GeV/c^2)	Decay channels
$1^+(1^+)$	Z_b	$B\bar{B}^*$	π [10.75]	$\Upsilon(nS)\pi, h_b(nP)\pi, \eta_b(nS)\rho$
$1^+(1^+)$	Z'_b	$B^*\bar{B}^*$	π [10.79]	$\Upsilon(nS)\pi, h_b(nP)\pi, \eta_b(nS)\rho$
$1^-(0^+)$	W_{b0}	$B\bar{B}$	ρ [11.34], γ [10.56]	$\Upsilon(nS)\rho, \eta_b(nS)\pi$
$1^-(0^+)$	W'_{b0}	$B^*\bar{B}^*$	ρ [11.43], γ [10.65]	$\Upsilon(nS)\rho, \eta_b(nS)\pi$
$1^-(1^+)$	W_{b1}	$B\bar{B}^*$	ρ [11.38], γ [10.61]	$\Upsilon(nS)\rho$
$1^-(2^+)$	W_{b2}	$B^*\bar{B}^*$	ρ [11.43], γ [10.65]	$\Upsilon(nS)\rho$
$0^-(1^+)$	X_{b1}	$B\bar{B}^*$	η [11.15]	$\Upsilon(nS)\eta, \eta_b(nS)\omega$
$0^-(1^+)$	X'_{b1}	$B^*\bar{B}^*$	η [11.20]	$\Upsilon(nS)\eta, \eta_b(nS)\omega$
$0^+(0^+)$	X_{b0}	$B\bar{B}$	ω [11.34], γ [10.56]	$\Upsilon(nS)\omega, \eta_b(nS)\eta$
$0^+(0^+)$	X'_{b0}	$B^*\bar{B}^*$	ω [11.43], γ [10.65]	$\Upsilon(nS)\omega, \eta_b(nS)\eta$
$0^+(1^+)$	X_b	$B\bar{B}^*$	ω [11.39], γ [10.61]	$\Upsilon(nS)\omega$
$0^+(2^+)$	X_{b2}	$B^*\bar{B}^*$	ω [11.43], γ [10.65]	$\Upsilon(nS)\omega$

The Success of Cornell Potential for Quarkonia

Exotics: Heavy Pentaquarks and Tetraquarks
 Ahmed Ali, Jens Soren Lange, and Sheldon Stone
 Progress in Particle and Nuclear Physics
 Volume 97, November 2017, Pages 123-198

$$V_0^{c\bar{c}}(r) = -\frac{4\alpha_s}{3r} + br + \frac{32\pi\alpha_s}{9m_c^2}\delta_\sigma(r)\vec{S}_c \cdot \vec{S}_{\bar{c}}$$

$$V_{\alpha_s}^{c\bar{c}}(r) = \frac{1}{m_c^2} \left[\left(\frac{2\alpha_s}{r^3} - \frac{b}{2r} \right) \vec{L} \cdot \vec{S} + \frac{4\alpha_s}{r^3} T \right]$$

$$\vec{T} \equiv (\vec{S}_c \cdot \hat{r})(\vec{S}_{\bar{c}} \cdot \hat{r}) - \frac{1}{3}\vec{S}_c \cdot \vec{S}_{\bar{c}}$$

T. Barnes, S. Godfrey, E. S. Swanson, Higher charmonia, Phys. Rev. D72 (2005) 054026. [arXiv: hep-ph/0505002](https://arxiv.org/abs/hep-ph/0505002), [doi:10.1103/PhysRevD.72.054026](https://doi.org/10.1103/PhysRevD.72.054026).

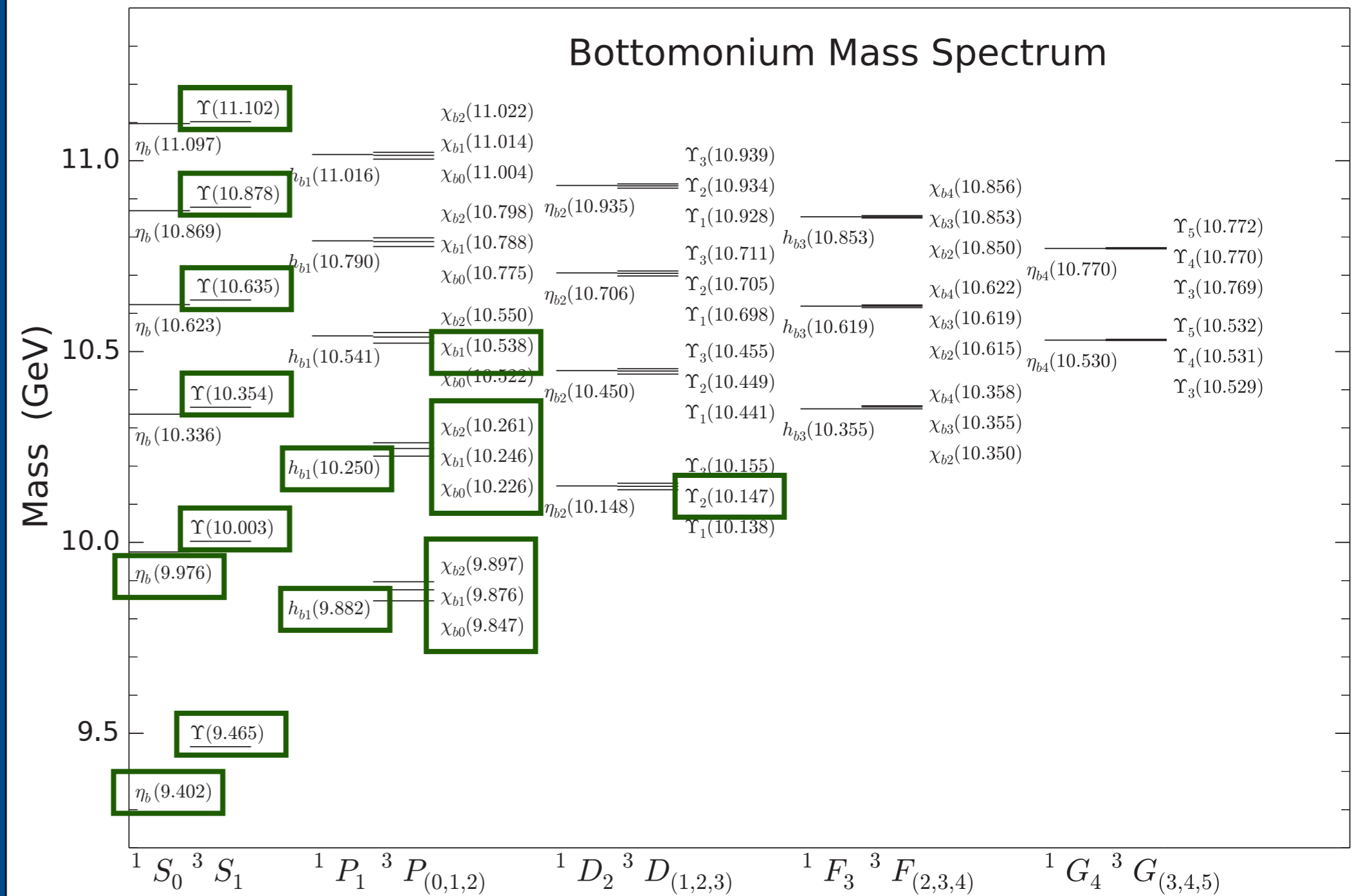

S. Godfrey and K. Moats, Bottomonium mesons and strategies for their observation, Phys. Rev. D 92, 054034 (2015)
 S. Godfrey and N. Isgur, Mesons in a relativized quark model with chromodynamics, Phys. Rev. D 32, 189 (1985).

Additional Molecular States in Bottomonium-like Spectroscopy

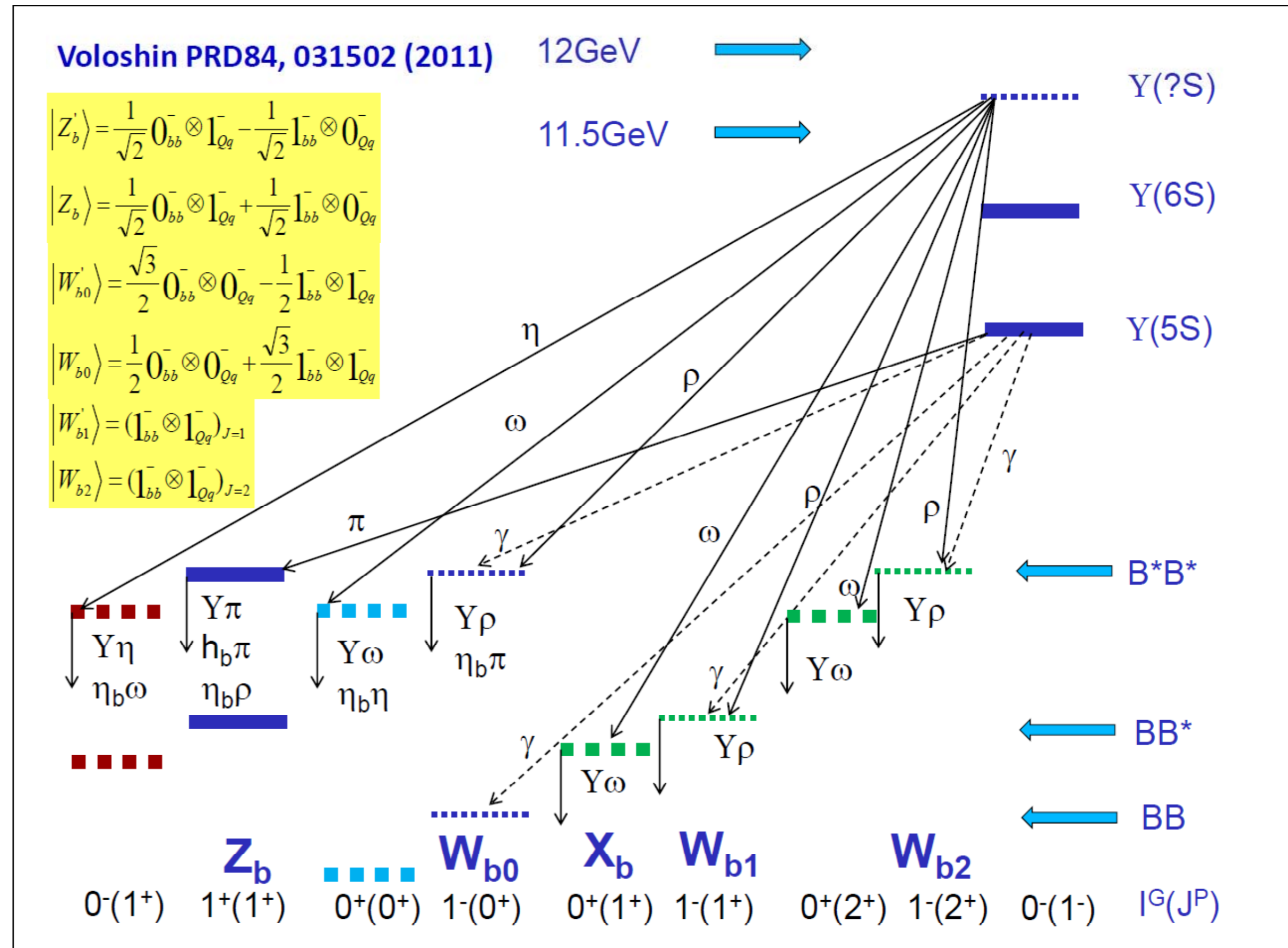
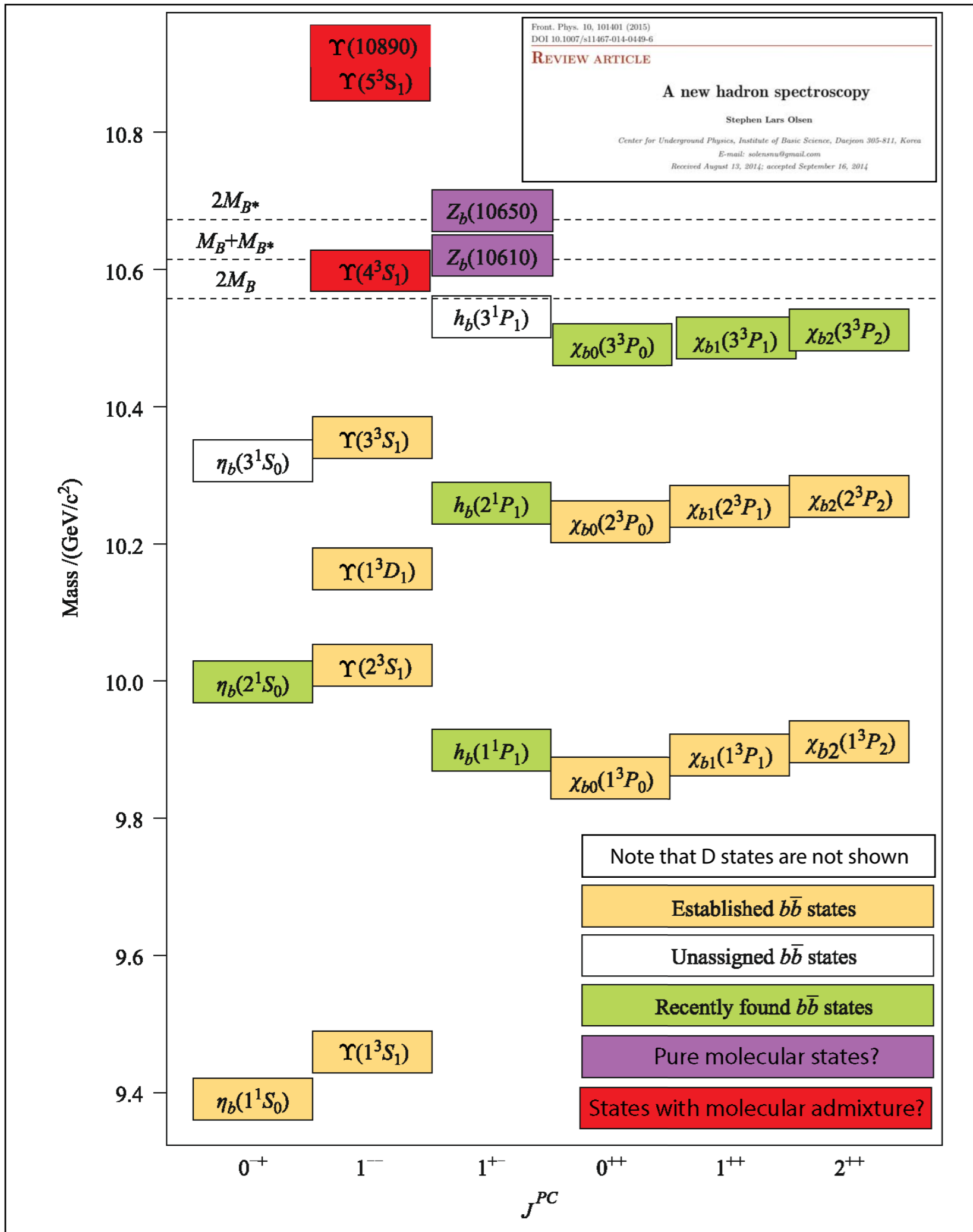

Additional Molecular States in Bottomonium-like Spectroscopy

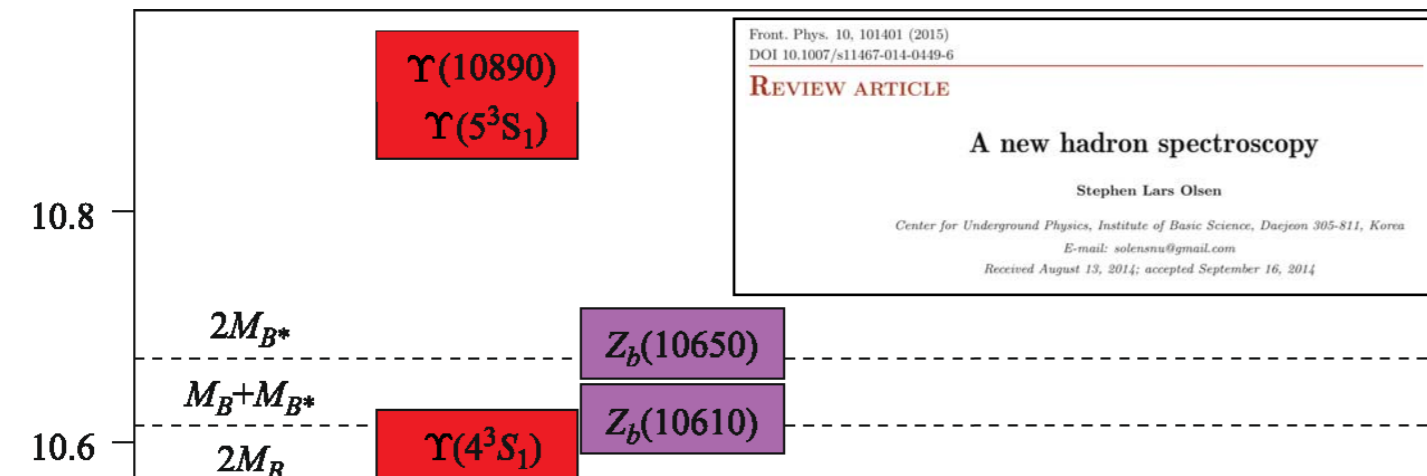

Front. Phys. 10, 101401 (2015)
DOI 10.1007/s11467-014-0449-6
REVIEW ARTICLE
A new hadron spectroscopy
Stephen Lars Olsen
Center for Underground Physics, Institute of Basic Science, Daejeon 305-811, Korea
E-mail: solsenus@gmail.com
Received August 13, 2014; accepted September 16, 2014

PHYSICAL REVIEW D **84**, 031502(R) (2011)
Radiative transitions from $\Upsilon(5S)$ to molecular bottomonium
M. B. Voloshin
William I. Fine Theoretical Physics Institute, University of Minnesota, Minneapolis, Minnesota 55455, USA
and Institute of Theoretical and Experimental Physics, Moscow, 117218, Russia
(Received 16 June 2011; published 29 August 2011)

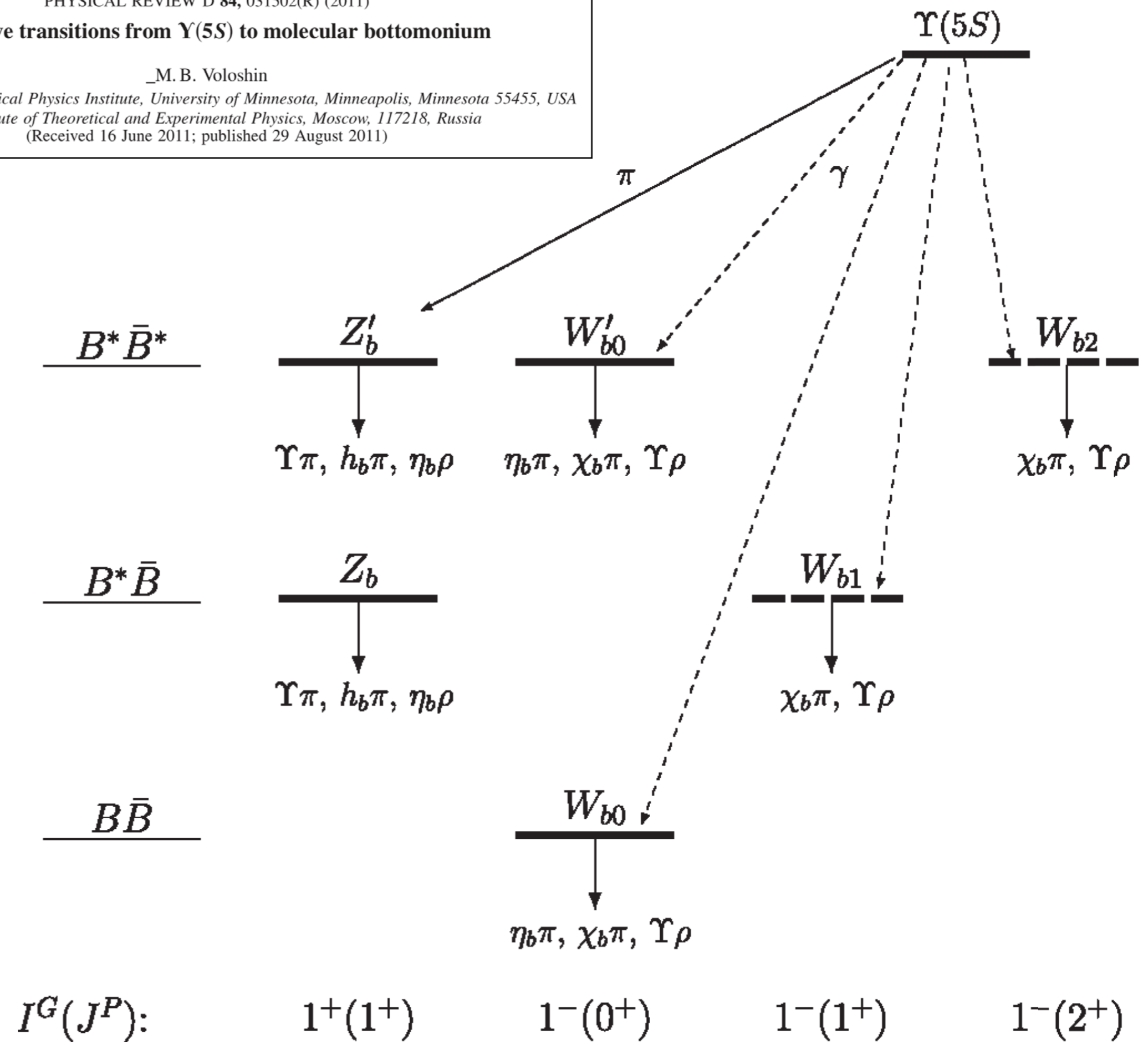
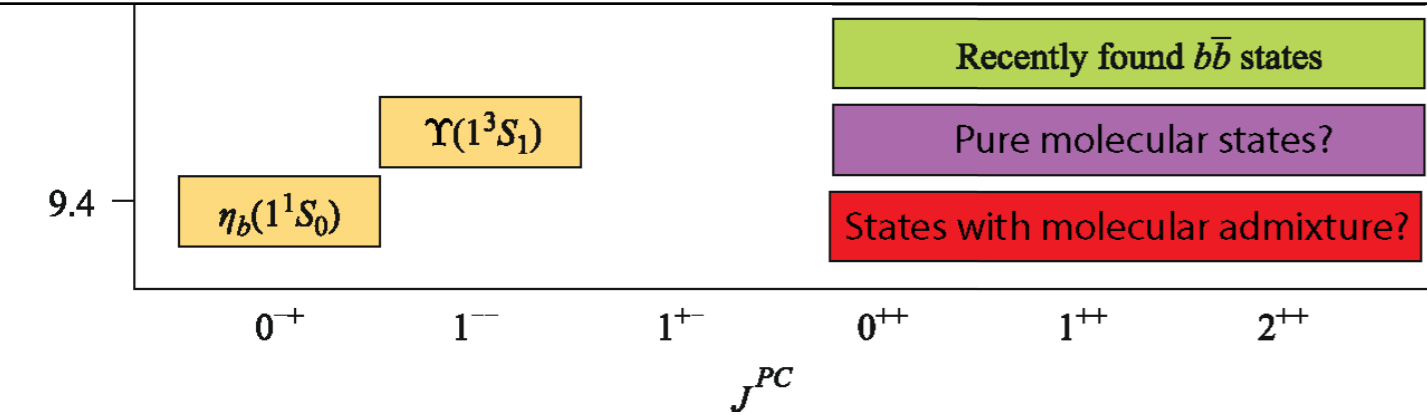
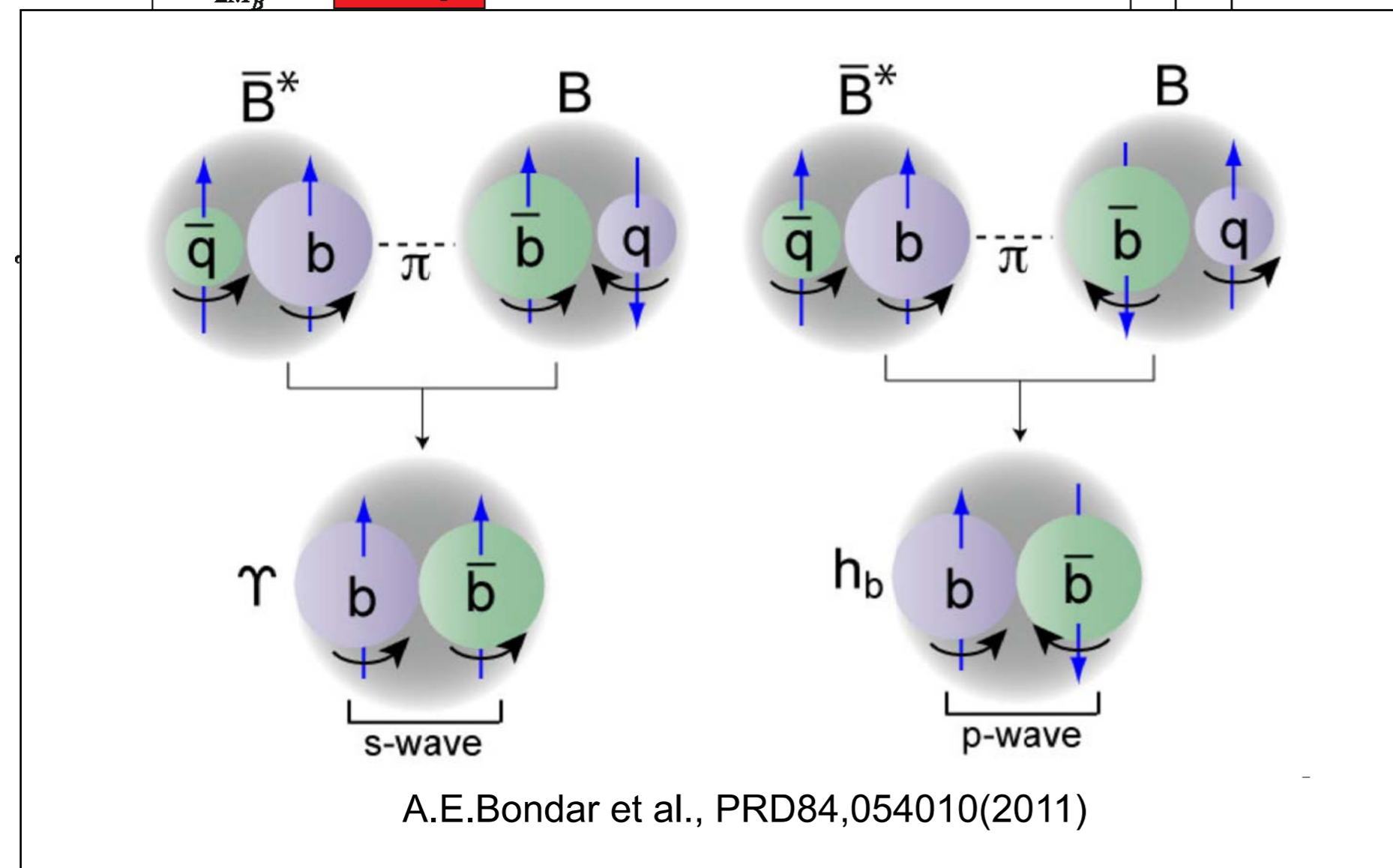

Search for Additional Molecular States at BB Thresholds

Table 132: Expected molecular states with the structure $B\bar{B}$, $B\bar{B}^*$ and $B^*\bar{B}^*$ [1377].

$I^G(J^P)$	Name	Content	Co-produced particles [Threshold, GeV/ c^2]	Decay channels
$1^+(1^+)$	Z_b	$B\bar{B}^*$	π [10.75]	$\Upsilon(nS)\pi, h_b(nP)\pi, \eta_b(nS)\rho$
$1^+(1^+)$	Z'_b	$B^*\bar{B}^*$	π [10.79]	$\Upsilon(nS)\pi, h_b(nP)\pi, \eta_b(nS)\rho$
$1^-(0^+)$	W_{b0}	$B\bar{B}$	ρ [11.34], γ [10.56]	$\Upsilon(nS)\rho, \eta_b(nS)\pi$
$1^-(0^+)$	W'_{b0}	$B^*\bar{B}^*$	ρ [11.43], γ [10.65]	$\Upsilon(nS)\rho, \eta_b(nS)\pi$
$1^-(1^+)$	W_{b1}	$B\bar{B}^*$	ρ [11.38], γ [10.61]	$\Upsilon(nS)\rho$
$1^-(2^+)$	W_{b2}	$B^*\bar{B}^*$	ρ [11.43], γ [10.65]	$\Upsilon(nS)\rho$
$0^-(1^+)$	X_{b1}	$B\bar{B}^*$	η [11.15]	$\Upsilon(nS)\eta, \eta_b(nS)\omega$
$0^-(1^+)$	X'_{b1}	$B^*\bar{B}^*$	η [11.20]	$\Upsilon(nS)\eta, \eta_b(nS)\omega$
$0^+(0^+)$	X_{b0}	$B\bar{B}$	ω [11.34], γ [10.56]	$\Upsilon(nS)\omega, \chi_{bJ}(nP)\pi^+\pi^-, \eta_b(nS)\eta$
$0^+(0^+)$	X'_{b0}	$B^*\bar{B}^*$	ω [11.43], γ [10.65]	$\Upsilon(nS)\omega, \chi_{bJ}(nP)\pi^+\pi^-, \eta_b(nS)\eta$
$0^+(1^+)$	X_b	$B\bar{B}^*$	ω [11.39], γ [10.61]	$\Upsilon(nS)\omega, \chi_{bJ}(nP)\pi^+\pi^-$
$0^+(2^+)$	X_{b2}	$B^*\bar{B}^*$	ω [11.43], γ [10.65]	$\Upsilon(nS)\omega, \chi_{bJ}(nP)\pi^+\pi^-$

Search for Missing Conventional Bottomonia

Table 131: Missing bottomonium levels below the $B\bar{B}$ threshold, their quantum numbers, potential model predictions for masses [1228], light hadrons emitted in the transitions from vector bottomonium-like states to the considered bottomonia and thresholds of these transitions [1377].

Name	L	S	J^{PC}	Mass, MeV/c^2	Emitted hadrons [Threshold, GeV/c^2]
$\eta_b(3S)$	0	0	0^{-+}	10336	ω [11.12], ϕ [11.36]
$h_b(3P)$	1	0	1^{+-}	10541	$\pi^+\pi^-$ [10.82], η [11.09], η' [11.50]
$\eta_{b2}(1D)$	2	0	2^{-+}	10148	ω [10.93], ϕ [11.17]
$\eta_{b2}(2D)$	2	0	2^{-+}	10450	ω [11.23], ϕ [11.47]
$\Upsilon_J(2D)$	2	1	$(1, 2, 3)^{--}$	10441 – 10455	$\pi^+\pi^-$ [10.73], η [11.00], η' [11.41]
$h_{b3}(1F)$	3	0	3^{+-}	10355	$\pi^+\pi^-$ [10.63], η [10.90], η' [11.31]
$\chi_{bJ}(1F)$	3	1	$(2, 3, 4)^{++}$	10350 – 10358	ω [11.14], ϕ [11.38]
$\eta_{b4}(1G)$	4	0	4^{-+}	10530	ω [11.31], ϕ [11.55]
$\Upsilon_J(1G)$	4	1	$(3, 4, 5)^{--}$	10529 – 10532	$\pi^+\pi^-$ [10.81], η [11.08], η' [11.49]

Search for the P_s^+ pentaquark (motivated by LHCb discoveries)

R. Aaij *et al.* (LHCb Collaboration), Observation of $J/\psi p$ resonances consistent with pentaquark states in $\Lambda_b^0 \rightarrow J/\psi K^- p$ decays, Phys. Rev. Lett. **115**, 072001 (2015).

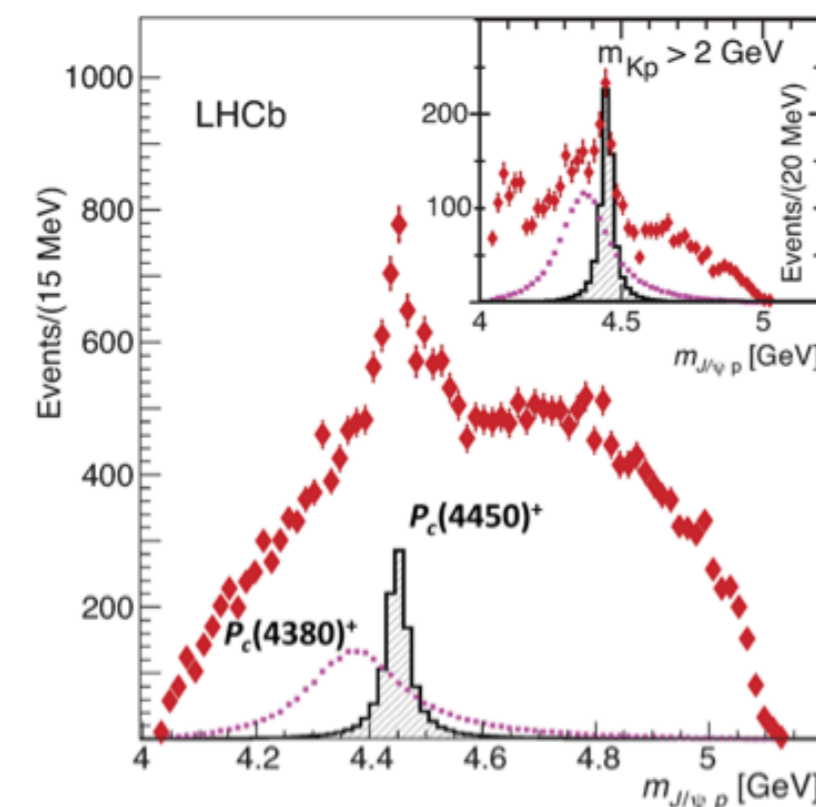

Hidden charm

Hidden strangeness

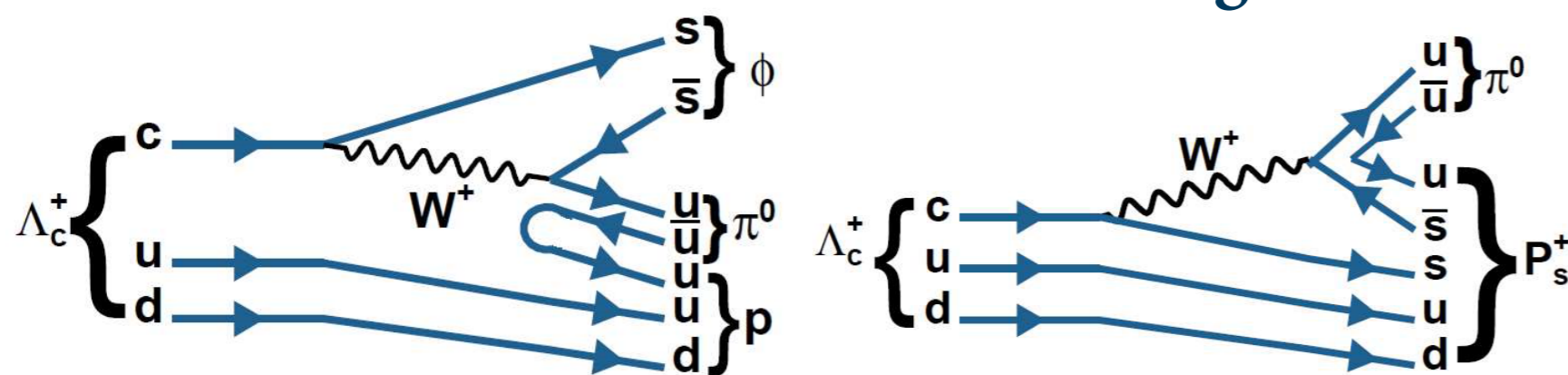

From 2D fit with three components in each bin of shown invariant mass

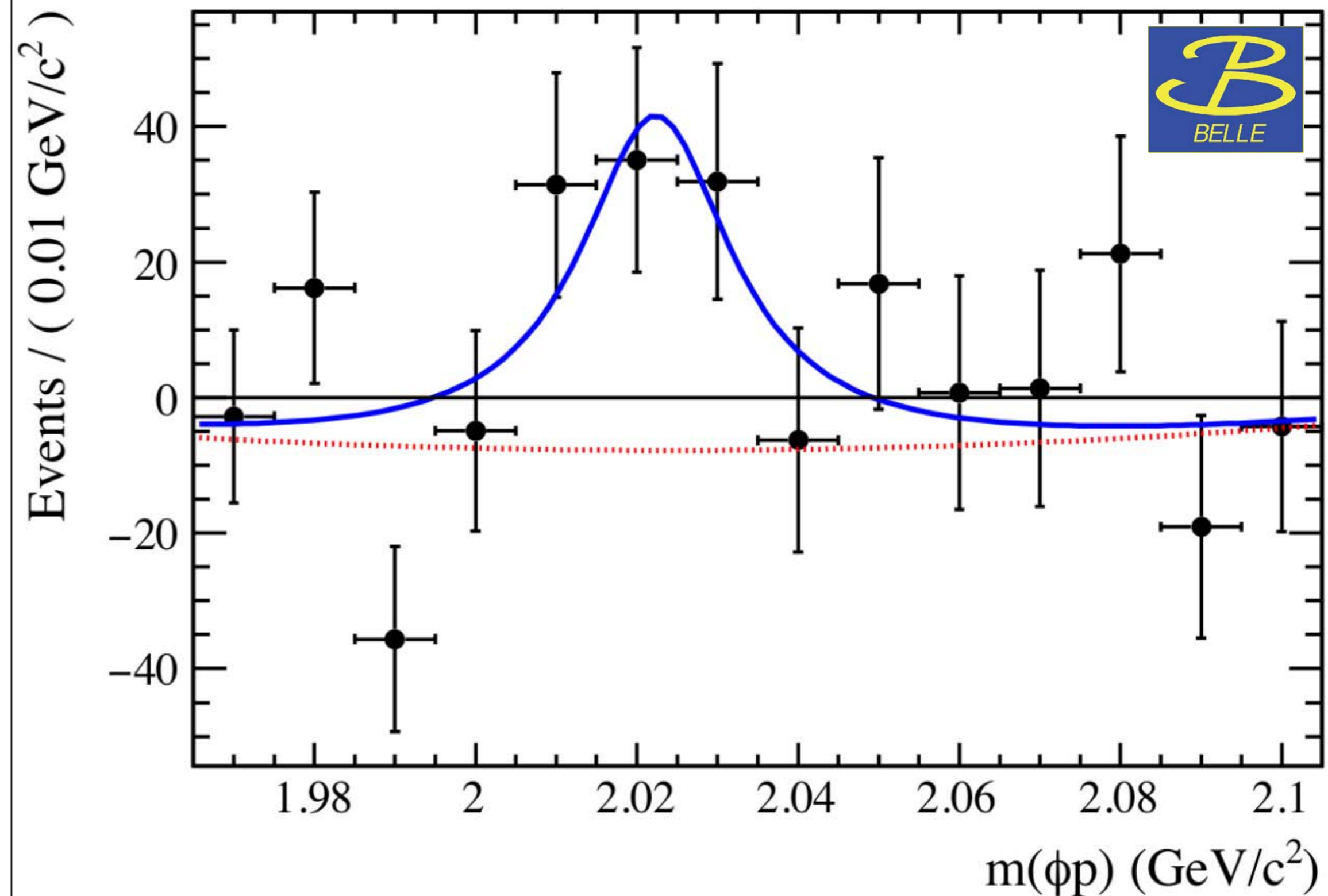

$$\mathcal{B}(\Lambda_c^+ \rightarrow P_s^+ \pi^0) \times \mathcal{B}(P_s^+ \rightarrow \phi p) < 8.3 \times 10^{-5}$$

B. Pal, A. J. Schwartz, et al. (Belle Collaboration), Phys. Rev. **D96**, 051102 (2017)

(Selected) Prospects in Baryon Spectroscopy

- Mesons get all the attention...
- Baryon spectrum is much more complicated than quarkonia **but exotic candidates exist even in the first excited states**
 - Notable examples include the $\Lambda(1405)$ and $N(1440)$
- Excited spectrum not well understood
 - Many missing states
 - Multiple candidates for known states
 - Few quantum number determinations for baryons containing c or b quarks
- Belle still actively publishing
- Belle II can
 - measure quantum numbers for excited charmed baryons
 - search for excited baryons in charmed baryon decays
 - search for exotic candidate states

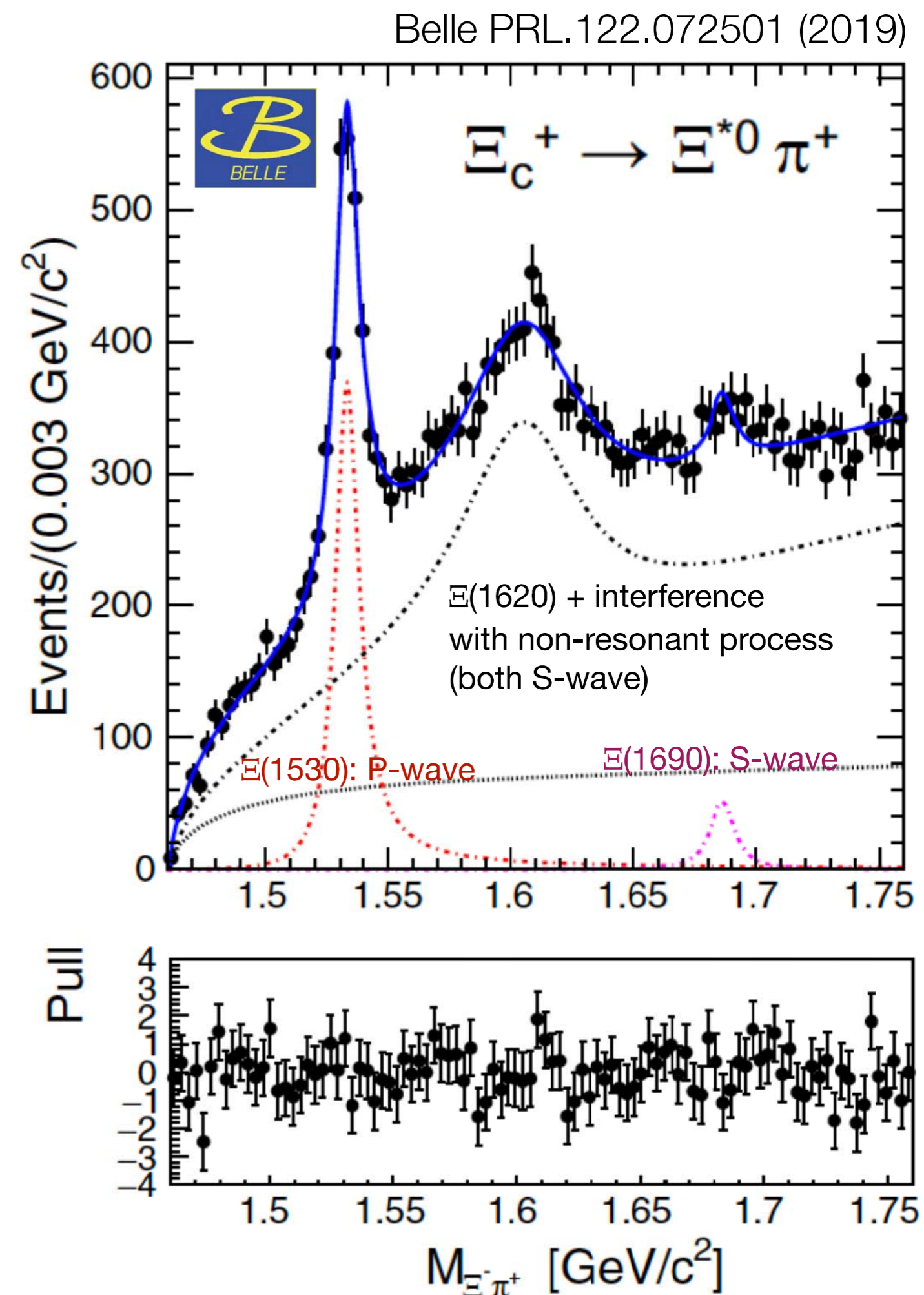
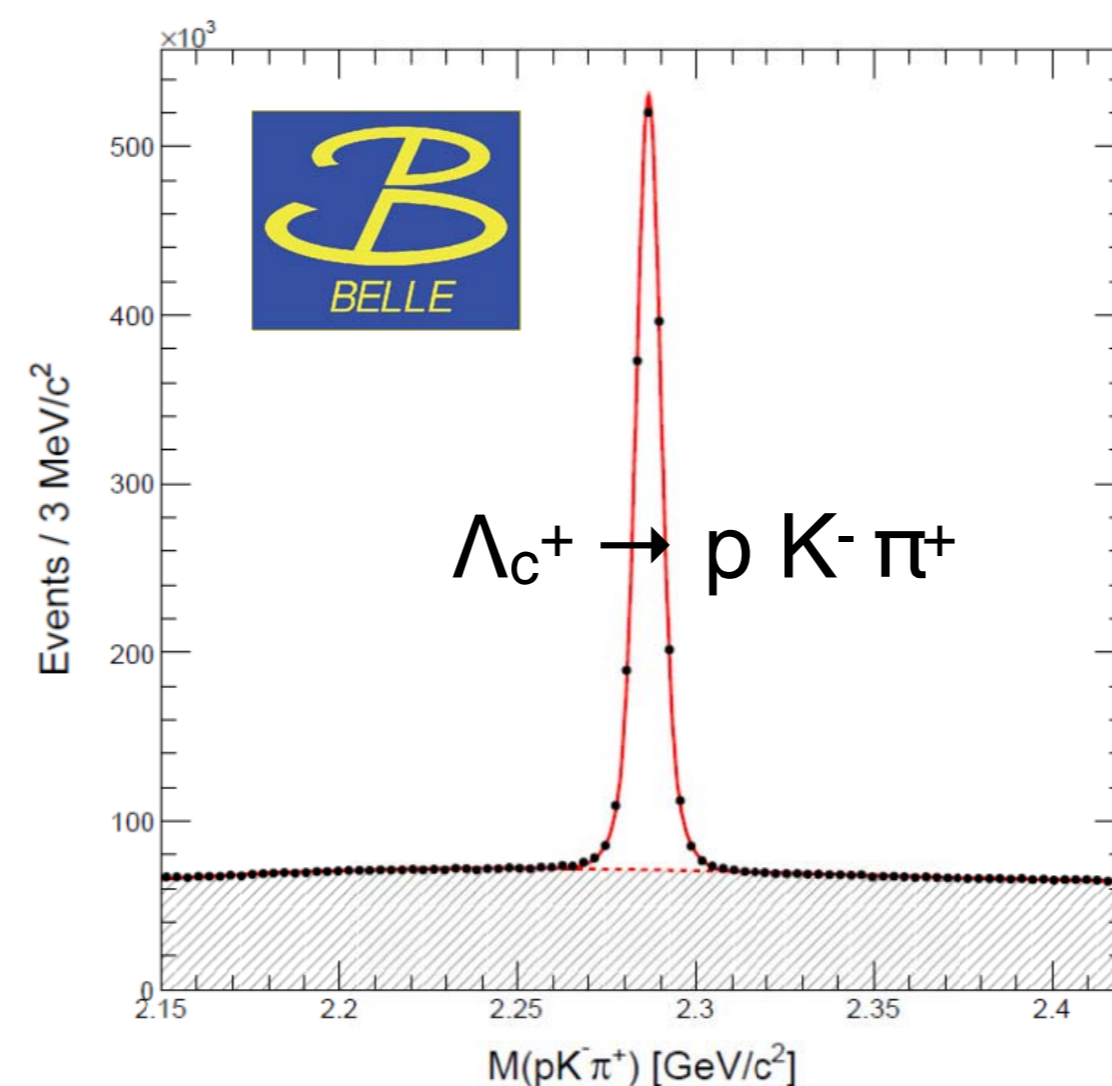

Belle II Λ_c Observation in 2018 Data

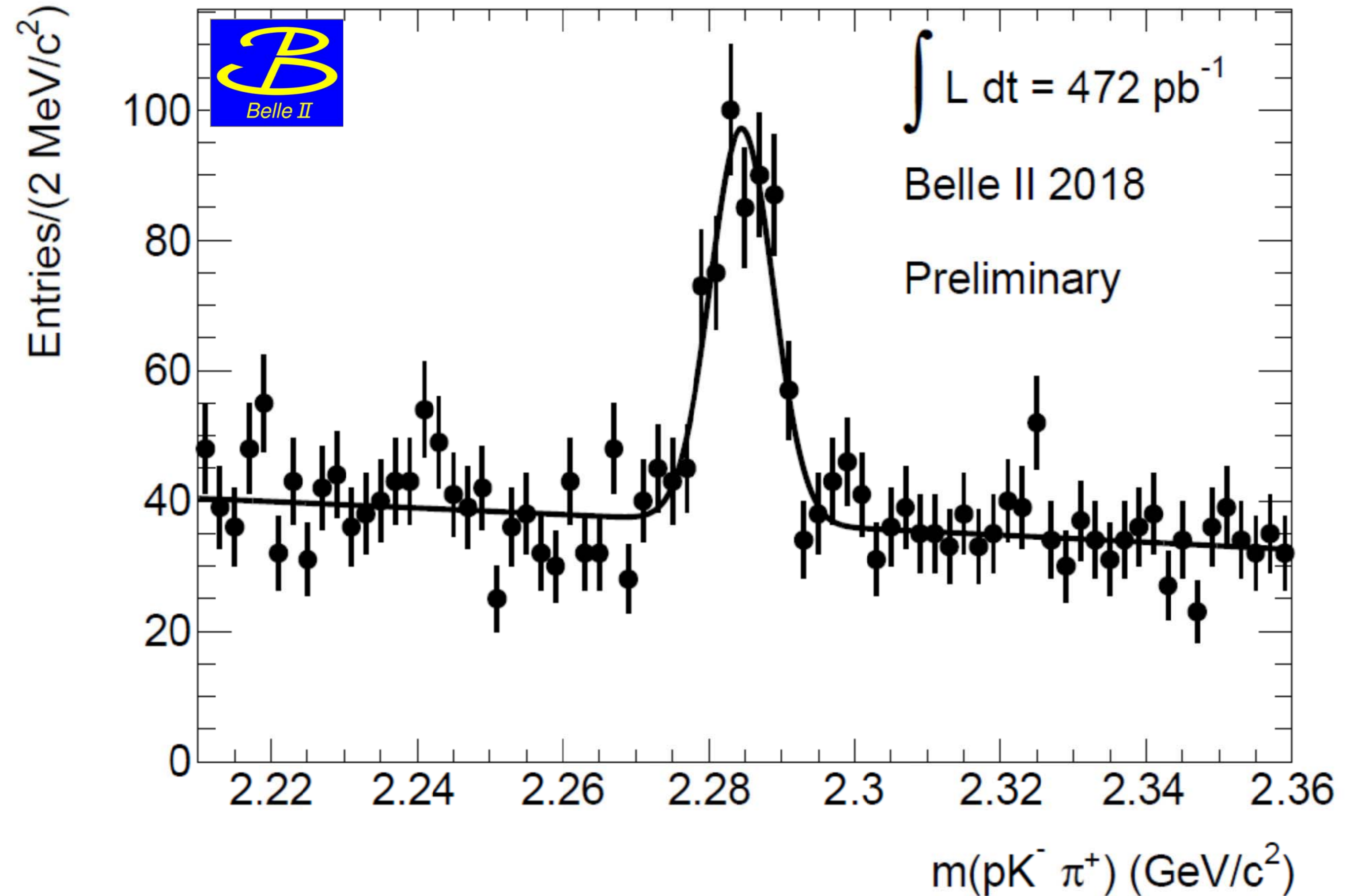

- Observed in combinations of $J=1$ and $J=0$
 $e^+e^- \rightarrow c\bar{c} (0+/-) c\bar{c} (1-/+)$

→ Belle II

- angular distributions, production
- probe for new states

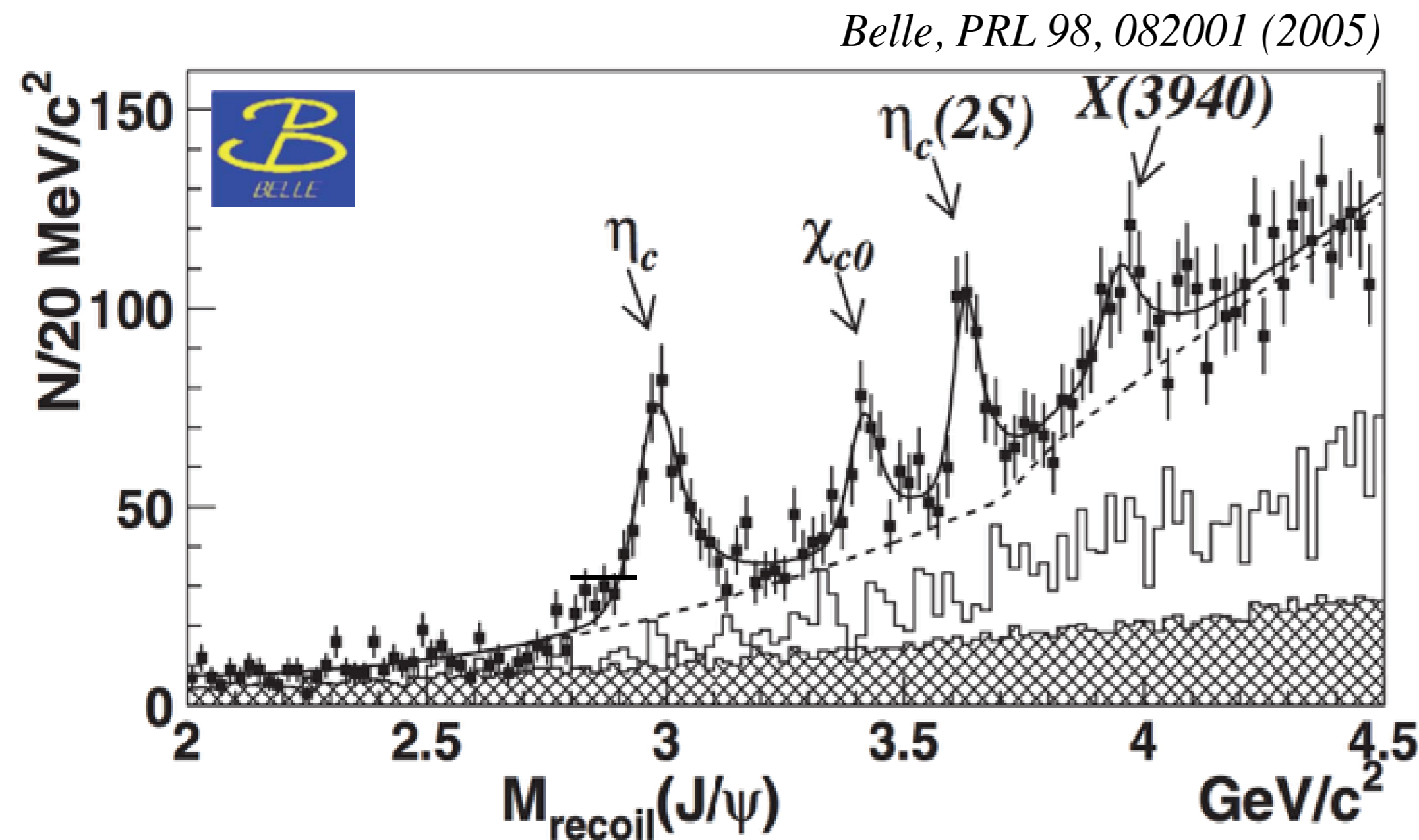

Also, from Belle II Physics Book (arXiv:1808.10567 [hep-ex]):

The discovery of a number of double-charmonium production processes in e^+e^- annihilation at B -factories was initiated by the observation of $e^+e^- \rightarrow J/\psi X$, where X is η_c , χ_{c0} , $\eta_c(2S)$ by Belle [1445]. This production mechanism provides a powerful tool for an understanding of the interplay between perturbative QCD (pQCD) (and its expansions beyond the leading order) and non-perturbative effects, in particular with application of the light-cone approximation and the nonrelativistic QCD (NRQCD) factorisation approaches. The first calculations using NRQCD within the leading order pQCD for the $e^+e^- \rightarrow J/\psi \eta_c$ cross-section gave a value, which was an order of magnitude smaller than the measured cross section [1446]. The importance of relativistic corrections was realised in Ref. [1447, 1448]; the authors, using the light-cone approximation to take into account the relative momentum of heavy quarks in the charmonium states, managed to calculate the cross section which is close to the experimental value. Some authors have been able to reproduce the experimental result using next-to-leading (NLO) corrections [1449, 1450]. The present variety of different alternative approaches that explain the experimental result points to the need to check the suggested models with new data.

Action Items for Belle II (directly from Belle II Physics Book)

- It is important to perform an energy scan from the $B\bar{B}$ threshold up to the highest possible energy with about 10 fb^{-1} per point, and to measure energy dependence of exclusive open flavour ($B\bar{B}$, $B\bar{B}^*$, $B^*\bar{B}^*$, $B^{(*)}\bar{B}^{(*)}\pi$, $B_s\bar{B}_s$ etc) and hidden flavour ($\Upsilon(nS)\pi^+\pi^-$, $h_b(nP)\pi^+\pi^-$, $\Upsilon(nS)\eta$, etc.) cross sections. This information is crucial for understanding vector bottomonium-like states. ①
- Collect data at $\Upsilon(6S)$ and at any new peak observed in the energy scan. These data will allow investigation of the decay mechanism of bottomonium-like states, search for missing conventional bottomonia, predicted bottomonium-like states and missing P -wave excitations of B_s mesons. ②

Observation of a New Structure in Energy Scan Between 10.52 and 11.02 GeV

arXiv:1905.05521v1 [hep-ex] 14 May 2019

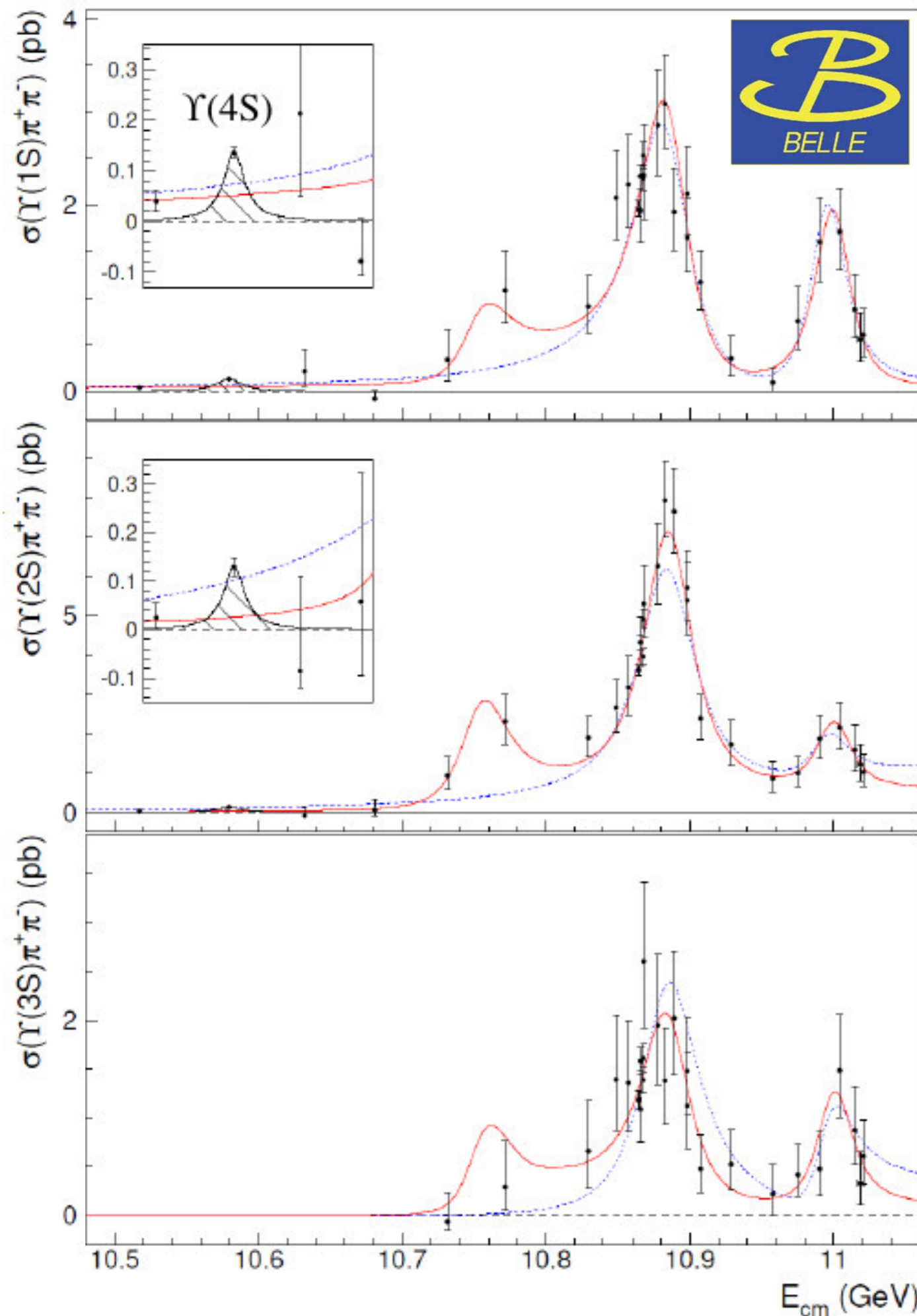

$$e^+e^- \rightarrow \Upsilon(nS)\pi^+\pi^- \quad (n = 1, 2, 3)$$

The new structure could have a resonant origin and correspond to a signal for the not yet observed $\Upsilon(3D)$ state provided $S - D$ mixing is enhanced [8], or an exotic state, e.g. a compact tetraquark [9] or hadrobottomonium [10]. It could also be a non-resonant effect due to some complicated rescattering. Information on the cross section energy dependence for more channels, with both hidden and open b flavor, is needed to clarify the nature of the new structure.

Can be done:

1. A study with higher statistics will be possible.
2. Study of $\Upsilon(5S)$ and $\Upsilon(6S)$ lineshapes in other channels



Action Items for Belle II (directly from Belle II Physics Book)

→ ○ Maximal energy of SuperKEKB is expected to be 11.24 GeV. The region above this energy is previously unexplored and it is of paramount importance to increase the energy. There is a $\Lambda_b\Lambda_b$ threshold at 11.24 GeV with potentially interesting baryon-antibaryon dynamics and more promising thresholds all the way up to 12 GeV. Transitions from new vector states provide possibly a unique way to produce partners of the $X(3872)$, $Z_b(10610)$ and $Z_b(10650)$. Most of relevant transitions are kinematically allowed if the mass of the vector state is above 11.5 GeV. ③

→ ○ Spin and parity of the quarkonium-like state are very important to discriminate various interpretations. For many states this information is missing. One should perform full amplitude analyses of the corresponding production processes to measure J^P . ④

→ ○ All quarkonium-like states are above the open flavour thresholds, and decay pattern into open flavour channels and corresponding line shapes are crucial for understanding of them. One should systematically search for open flavour decays of all quarkonium-like states. ⑤

Production Thresholds for Narrow S and P wave Mesons and Baryons

Target: $L = 8 \times 10^{35} / \text{cm}^2 / \text{s} = L_{\text{KEKB}} \times 40$

Promising energy regions

Particles	Threshold, GeV/c^2
$B^{(*)} \bar{B}^{**}$	11.00 – 11.07
$B_s^{(*)} \bar{B}_s^{**}$	11.13 – 11.26
$\Lambda_b \bar{\Lambda}_b$	11.24
$B^{**} \bar{B}^{**}$	11.44 – 11.49
$B_s^{**} \bar{B}_s^{**}$	11.48 – 11.68
$\Lambda_b \bar{\Lambda}_b^{**}$	11.53 – 11.54
$\Sigma_b^{(*)} \bar{\Sigma}_b^{(*)}$	11.62 – 11.67
$\Lambda_b^{**} \bar{\Lambda}_b^{**}$	11.82 – 11.84



Beam current: $\times 2$ (higher RF power); upgraded components shown in color
 Beam size: $1/20$ (low emittance, compact and strong focusing quads)

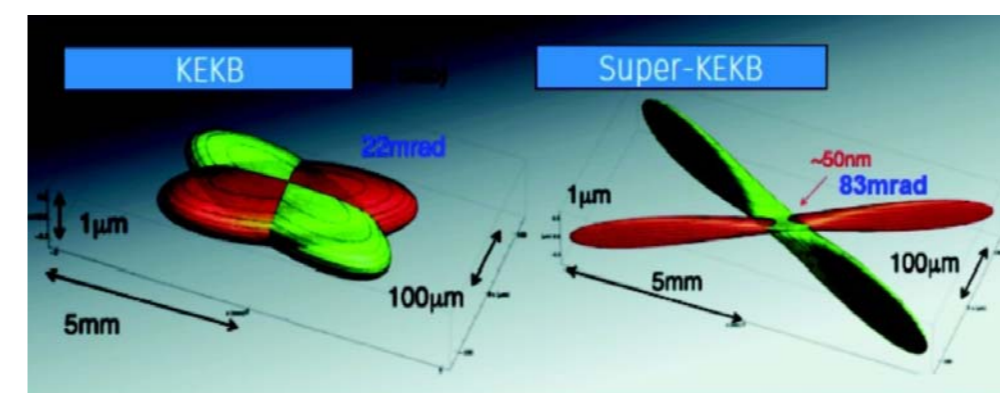
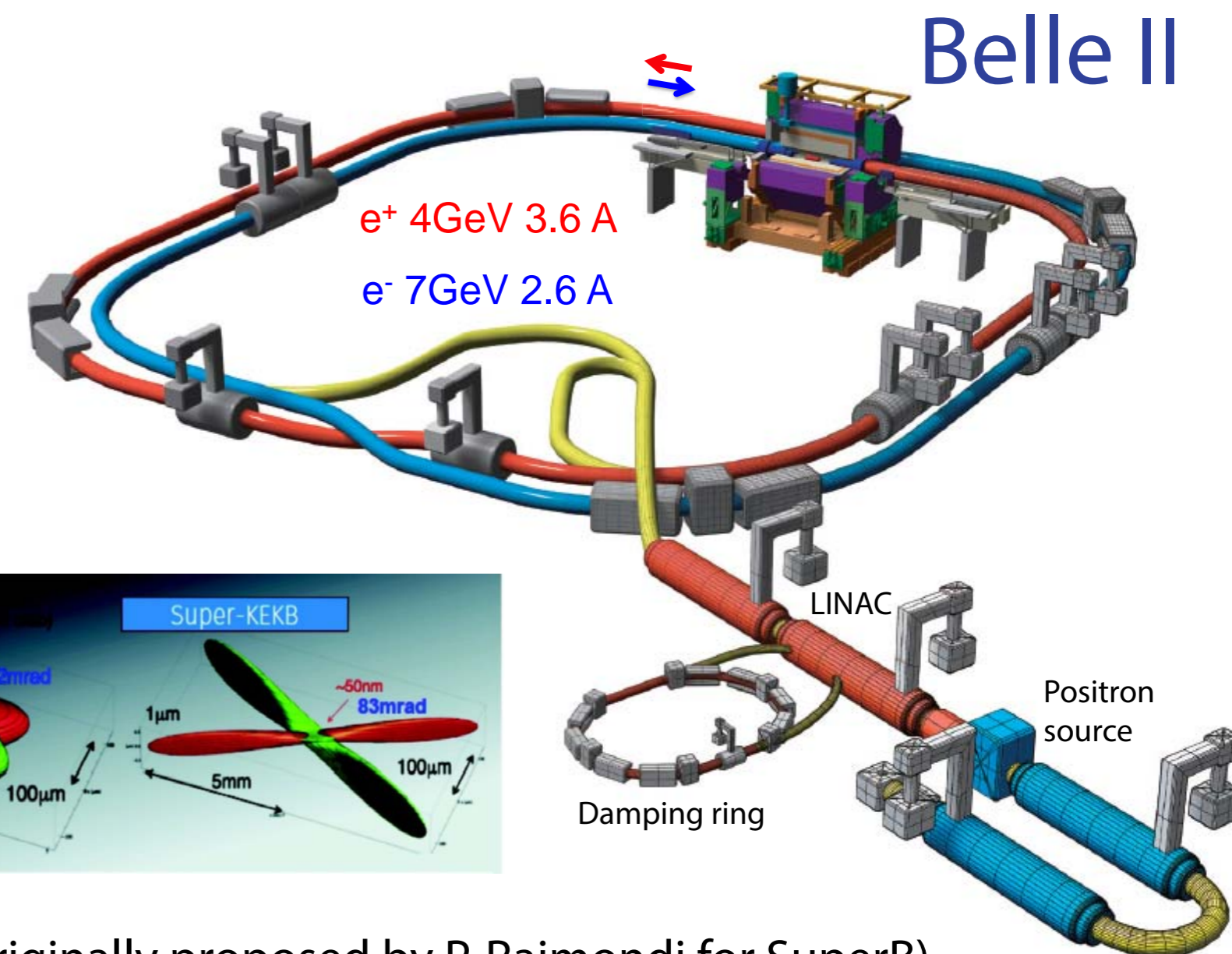

Nanobeams (originally proposed by P. Raimondi for SuperB)
 new positron target, reinforced RF cavities, redesigned lattices for LER & HER,
 LER: dipoles magnets replaced by longer ones,
 TiN-coated LER beampipe with antechambers,
 new superconducting focusing quadrupole magnets near IP

Action Items for theory (directly from Belle II Physics Book)

- Action items for phenomenological approaches

- ● Within all approaches to QCD exotics predictions should be provided for states with quantum numbers not yet observed. This could be done, *e.g.*, employing the heavy quark spin symmetry. At Belle those could be searched for in the decay chains of heavy vector states.
- ● For all predicted states quantitative statements about partial decay widths or at least branching ratios should be provided, not only allowing one to identify potential discovery modes but also as stringent test of the assumed dynamics.
- ● Predictions also for the bottom sector are necessary again for various quantum numbers.
- ● The mixing of exotic states with regular quarkonia needs to be investigated.

Action Items for theory (directly from Belle II Physics Book)

○ Action items for lattice QCD

- ➔ ● Calculate scattering matrices for $D_{(s)}^{(*)}\bar{D}_{(s)}^{(*)}$ and for *charmonium + light-hadron* with non-static heavy quarks. First in the one-channel approximation and then taking as many coupled channels as possible. Determine the position of poles in the scattering matrix and try to connect poles with the experimentally observed states.
- ➔ ● Approach bottomonium states close to $B^{(*)}\bar{B}^{(*)}$ threshold with non-static b-quarks and make an effort to take into account the effect of this threshold.
- ➔ ● Determine yet undetermined Born-Oppenheimer potentials for static heavy quarks using lattice QCD, for example those related to Z_b .
- ➔ ● Calculate yet undetermined radiative transitions between quarkonia below threshold. Try to make a step towards a rigorous treatment of this problem also for states above open-charm threshold.
- ➔ ● Consider effects of $\bar{Q}Q$ annihilation in lattice simulations.
- ➔ ● Consider effects of isospin breaking in lattice QCD for channels where it might be important, for example $X(3872)$.

Target: $L = 8 \times 10^{35} / \text{cm}^2 / \text{s} = L_{\text{KEKB}} \times 40$

Beam current: $\times 2$ (higher RF power); upgraded components shown in color
 Beam size: $1/20$ (low emittance, compact and strong focusing quads)

Belle II

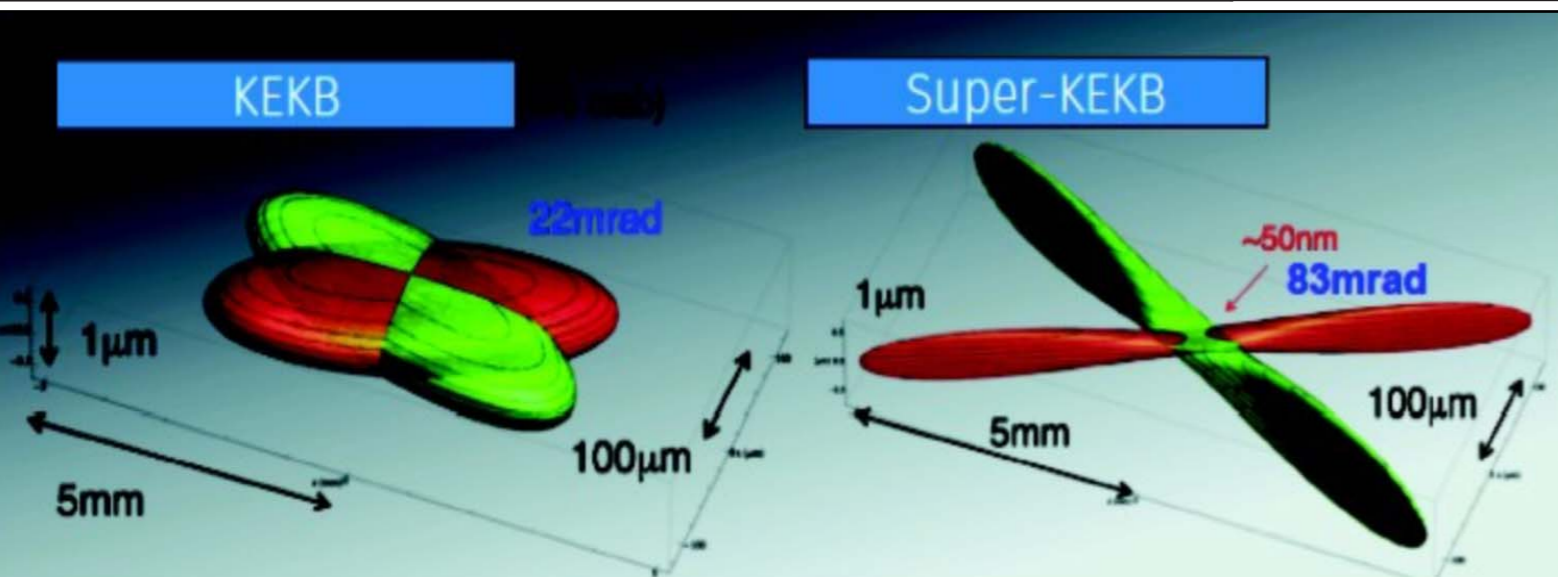
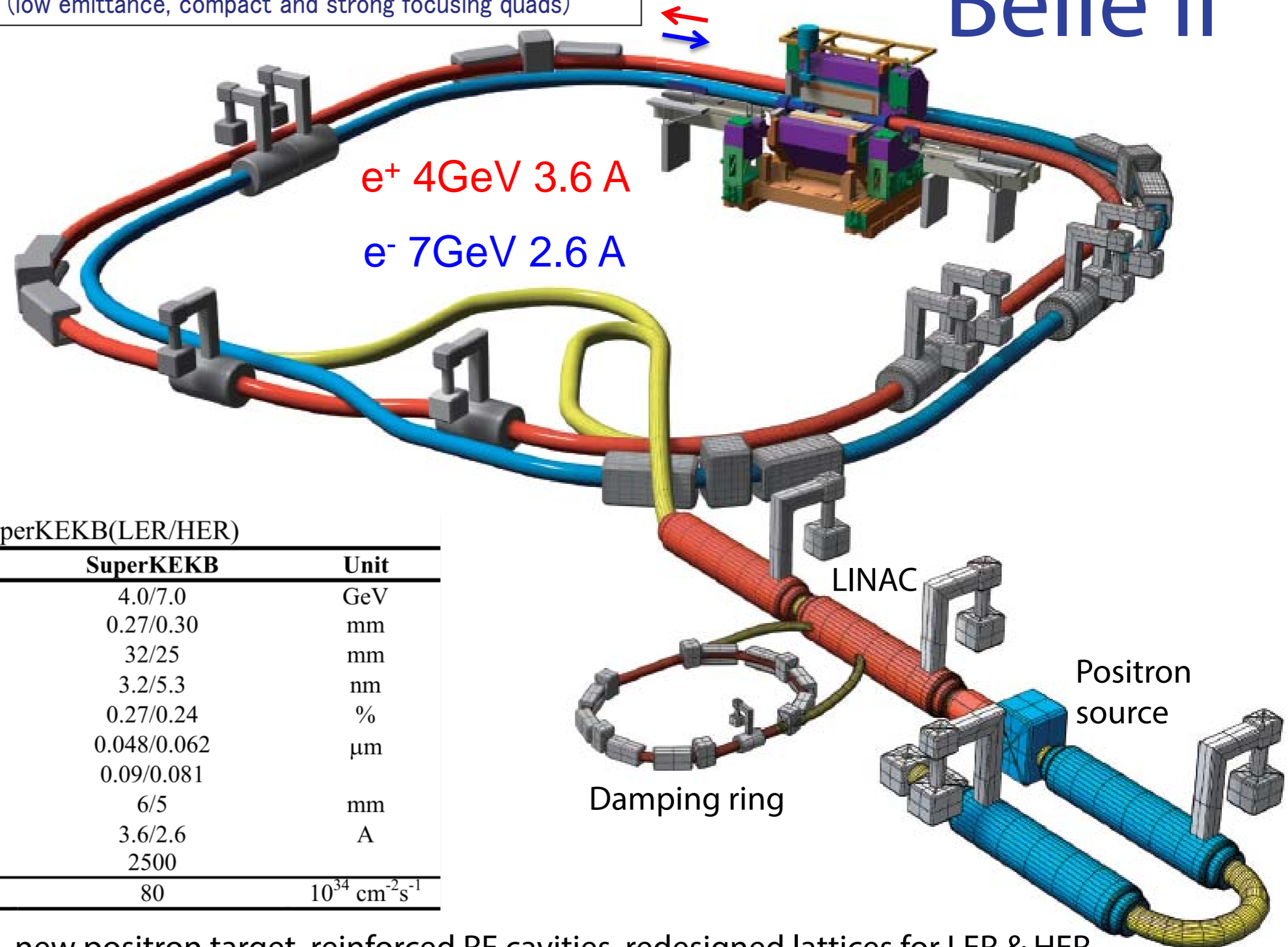

$$L = \frac{\gamma_{\pm}}{2er_e} \left(1 + \frac{\sigma_y^*}{\sigma_x^*} \right) \left(\frac{I_{\pm} \xi_{y\pm}}{\beta_{y\pm}^*} \right) \left(\frac{R_L}{R_{\xi y}} \right) \propto \frac{I_{\pm} \xi_{y\pm}}{\beta_{y\pm}^*}$$

Table 1: Machine parameters of KEKB (LER/HER) and SuperKEKB(LER/HER)

	KEKB design	KEKB Achieved: with crab	SuperKEKB	Unit
Energy	3.5/8.0	3.5/8.0	4.0/7.0	GeV
β_y^*	10/10	5.9/5.9	0.27/0.30	mm
β_x^*	330/330	1200/1200	32/25	mm
ϵ_x	18/18	18/24	3.2/5.3	nm
x-y coupling (ϵ_y/ϵ_x)	1	0.85/0.64	0.27/0.24	%
σ_y	1.9	0.94	0.048/0.062	μm
ξ_y	0.052	0.129/0.090	0.09/0.081	
σ_z	4	6-7	6/5	mm
I	2.6/1.1	1.64/1.19	3.6/2.6	A
N_{bunch}	5000	1584	2500	
Luminosity	1	2.11	80	$10^{34} \text{ cm}^{-2} \text{ s}^{-1}$

Nanobeams (originally proposed by P. Raimondi for SuperB), new positron target, reinforced RF cavities, redesigned lattices for LER & HER, LER: dipoles magnets replaced by longer ones, TiN-coated LER beampipe with antechambers, new superconducting focusing quadrupole magnets near IP

Boost: KEKB: $\beta\gamma = 0.425$
 SuperKEKB: $\beta\gamma = 0.28$

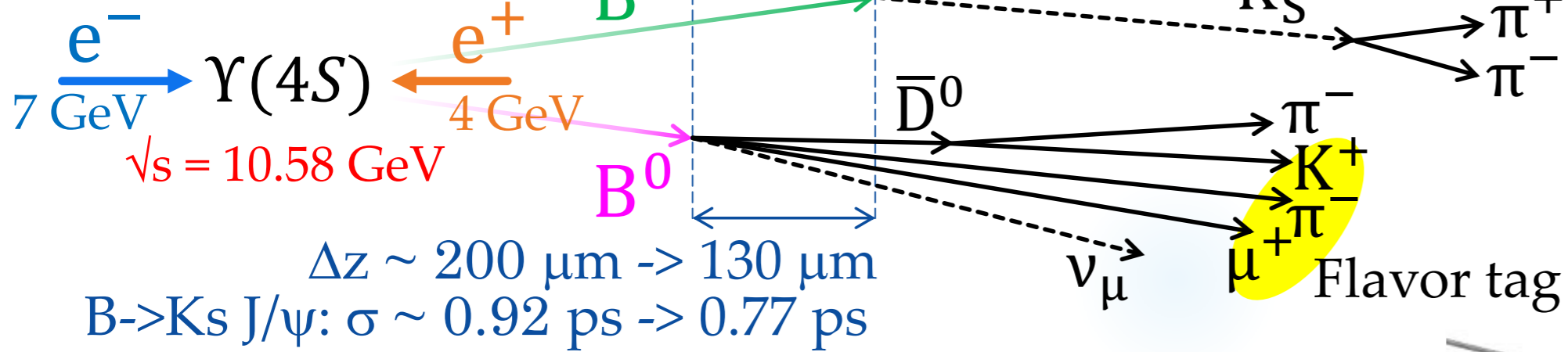

Beryllium beam pipe in the interaction region:

diameter decreased from 3cm to 2cm

Vertex detector (VXD): two layers of pixels followed by four double-layered silicon strips

Center drift chamber: smaller cells (than @Belle), faster electronics, improved triggering capabilities

PID: compact Time-of-Propagation (TOP) barrel and proximity focusing aerogel endcap
 Cherenkov detectors

EM calorimeter: Same CsI(Tl) crystals, upgraded electronics (shaper based on digital signal processing)

K_L and μ identification: RPCs replaced by scintillators in the endcap and two inner barrel layers, new electronics, triggering

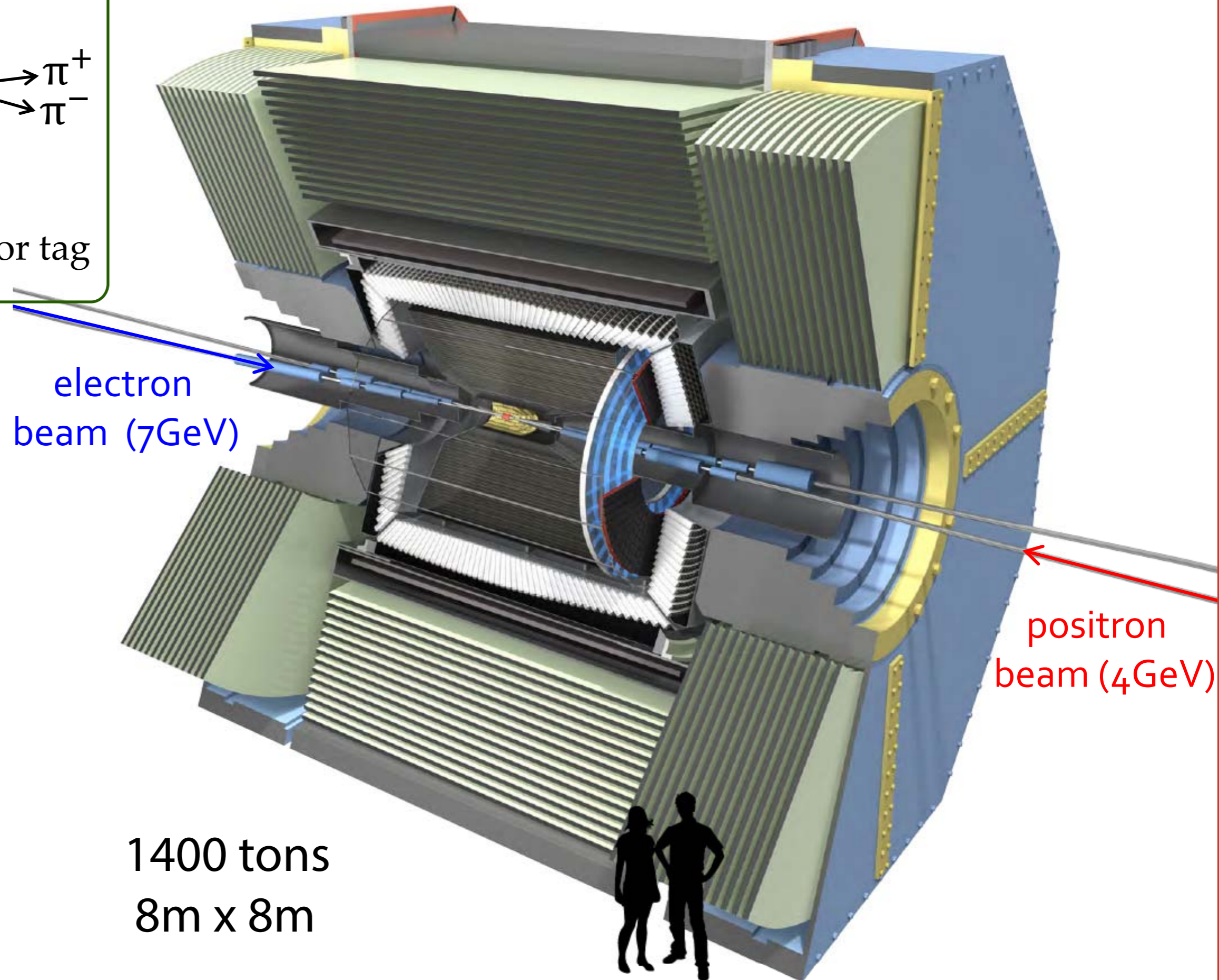

1400 tons
 8m x 8m

Boost: KEKB: $\beta\gamma = 0.425$
 SuperKEKB: $\beta\gamma = 0.28$

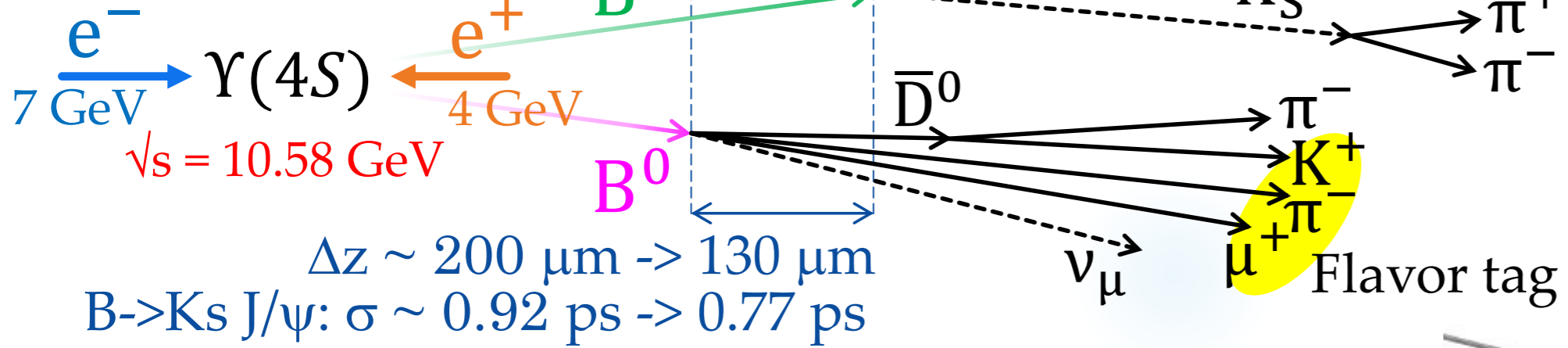

- Beryllium beam**: diameter decreased from 3cm to 2cm
 - Vertex detector (VXD)**: two layers of pixels followed by four double-layered silicon strips
 - Center drift chamber**: smaller cells (than @Belle), faster electronics
 - PID**: compact Time-of-Propagation (TOP) barrel and proximity focusing aerogel endcap
 - Cherenkov detector**
 - EM calorimeter**: Same CsI(Tl) crystals, upgraded electronics (shaper based on digital signal processing)
 - K_L and μ identification**: scintillators in the endcap and two inner barrel layers, new electronics, triggering
- VXD: beam-related background tolerant**
 - Improved impact parameter resolution**
 - Better z vertex resolution**
 - Approx. 30% better inv. mass resolution**
 - ~30% increase in K_S efficiency**
 - Improved K / π separation**
 - Decreased π fake rate by the factor of ~2.5**
 - Improved slow ($\sim 100\text{MeV}/c$) π reconstruction**
 - Improved π^0 reconstruction**

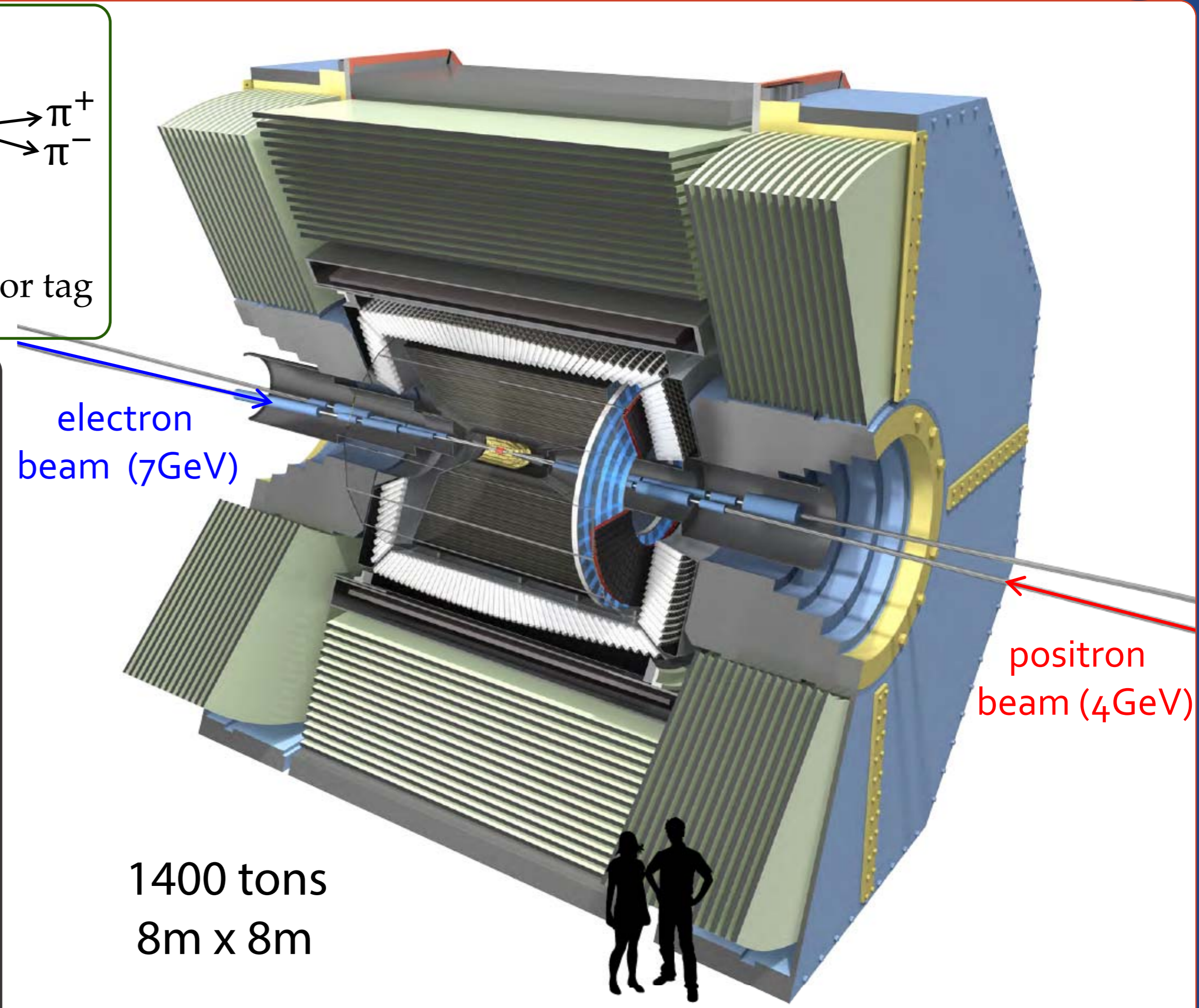

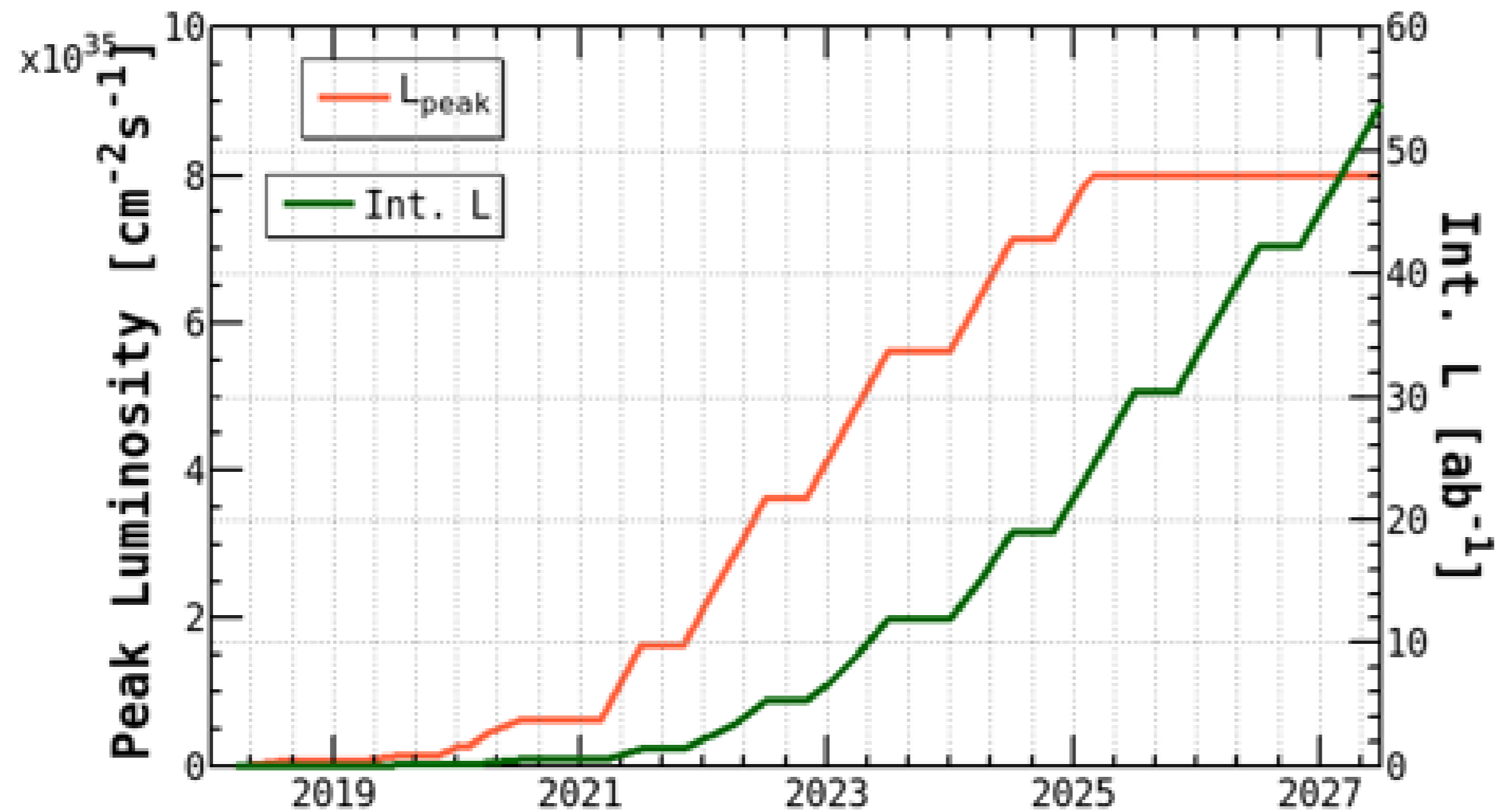

- ▶ Belle: 1 ab^{-1}
- ▶ Belle II:
- ▶ 5 ab^{-1} by ~ 2023
- ▶ 50 ab^{-1} by ~ 2028

Current samples in fb^{-1} (millions of events)

Experiment	$\Upsilon(1S)$	$\Upsilon(2S)$	$\Upsilon(3S)$	$\Upsilon(4S)$	$\Upsilon(5S)$	$\Upsilon(6S)$	$\frac{\Upsilon(nS)}{\Upsilon(4S)}$
CLEO	1.2 (21)	1.2 (10)	1.2 (5)	16 (17.1)	0.1 (0.4)	-	23%
BaBar	-	14 (99)	30 (122)	433 (471)	R_b scan	R_b scan	11%
Belle	6 (102)	25 (158)	3 (12)	711 (772)	121 (36)	5.5	23%
Belle II (proposed)			300 (1200)	5×10^4 (5.4×10^4)	1000 (300)	100+400 (scan)	3.6%

Conclusions / Summary

Significant increase in luminosity at Belle II will allow us to do an even better job than with Belle
There are many puzzles to solve, many states to search for and analyze, a large body of work to do

The Belle II Physics Book (arXiv:1808.10567) provides a roadmap of important studies to carry out
Future high precision measurements require close collaborations of experimentalists and theorists

Distinguishing between the models is cool, but our goals also include to provide data which could be used to develop a unified theoretical approach to long-distance strong-interaction physics →

This would facilitate theoretical progress in extracting NP from processes where QCD is involved

(please note that I omitted (without prejudice) some of the topics (e.g., $Y(3S)$ physics) from my slides)

A large number of very capable and talented physicists, engineers and technicians made it possible
I would like to thank them all: SuperKEKB, Belle II, theoretical community involved in B2TiP, everyone

First collisions (note that the collaboration is much larger)

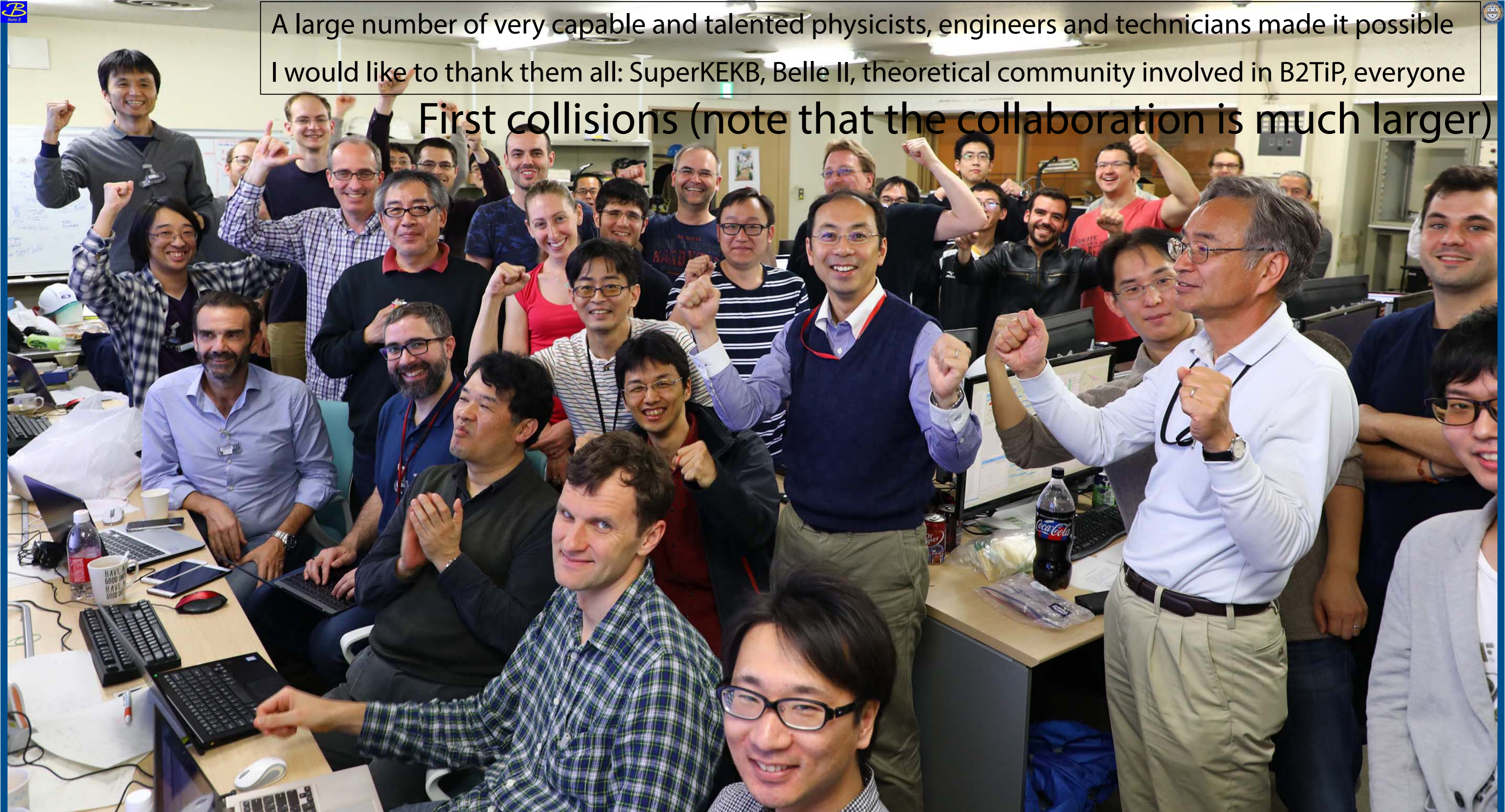



BACKUP
slides

Why 10.58 GeV? Mass of $\Upsilon(4S)$ (an $n=4$ bottomonium state)

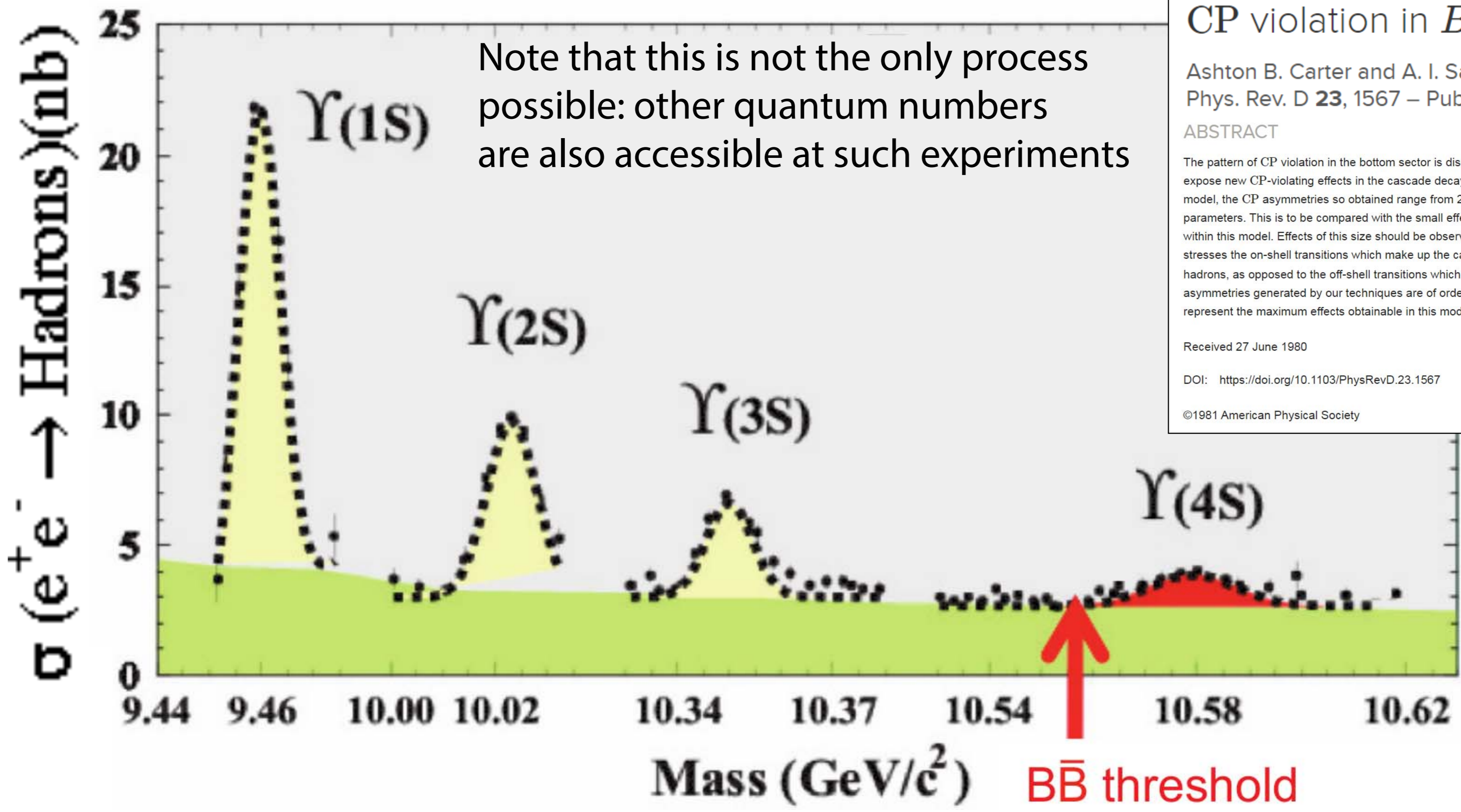

Note that this is not the only process possible: other quantum numbers are also accessible at such experiments

CP violation in B -meson decays

Ashton B. Carter and A. I. Sanda
 Phys. Rev. D **23**, 1567 – Published 1 April 1981

ABSTRACT

The pattern of CP violation in the bottom sector is discussed. We introduce general techniques to expose new CP-violating effects in the cascade decays of B mesons. In the Kobayashi-Maskawa (KM) model, the CP asymmetries so obtained range from 2-20% for plausible values of the model parameters. This is to be compared with the small effects, of order 10^{-3} - 10^{-4} , previously exhibited within this model. Effects of this size should be observable in upcoming experiments. Our approach stresses the on-shell transitions which make up the cascade decays of heavy mesons to ordinary hadrons, as opposed to the off-shell transitions which occur in the analogs of $K^0 - \bar{K}^0$ mixing. The CP asymmetries generated by our techniques are of order $\sin \delta$, where δ is the KM phase angle, and thus represent the maximum effects obtainable in this model.

Received 27 June 1980

DOI: <https://doi.org/10.1103/PhysRevD.23.1567>

©1981 American Physical Society

Why 10.58 GeV? Mass of $\Upsilon(4S)$ (an $n=4$ bottomonium state)

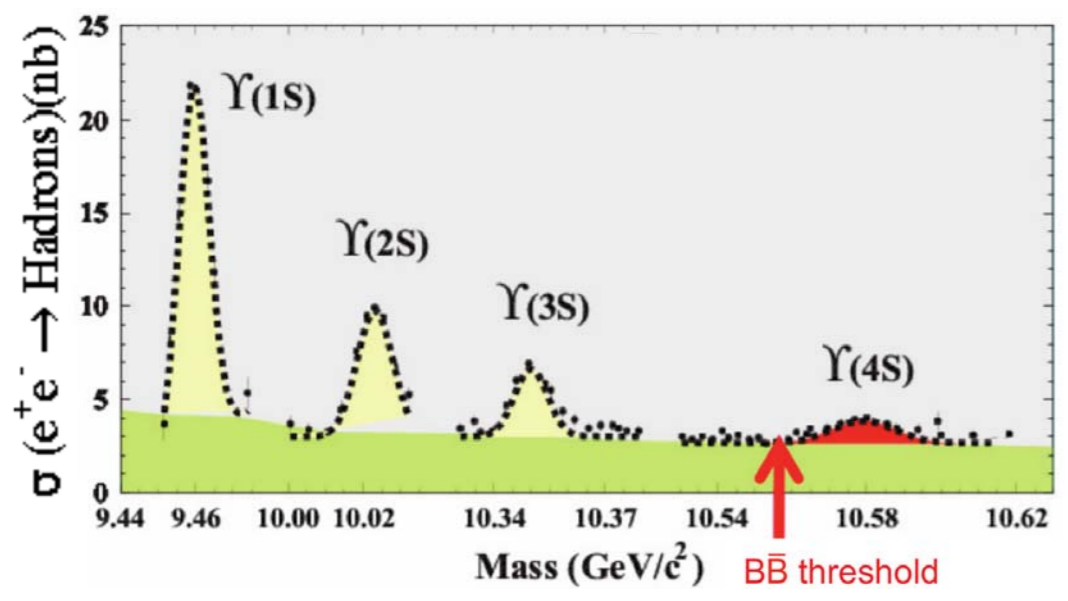

Asymmetry between the energies of the beams increases the distance between the decay vertices of the two B mesons therefore making the measurement of oscillations possible

Boost: KEKB: $\beta\gamma = 0.425$
 SuperKEKB: $\beta\gamma = 0.28$

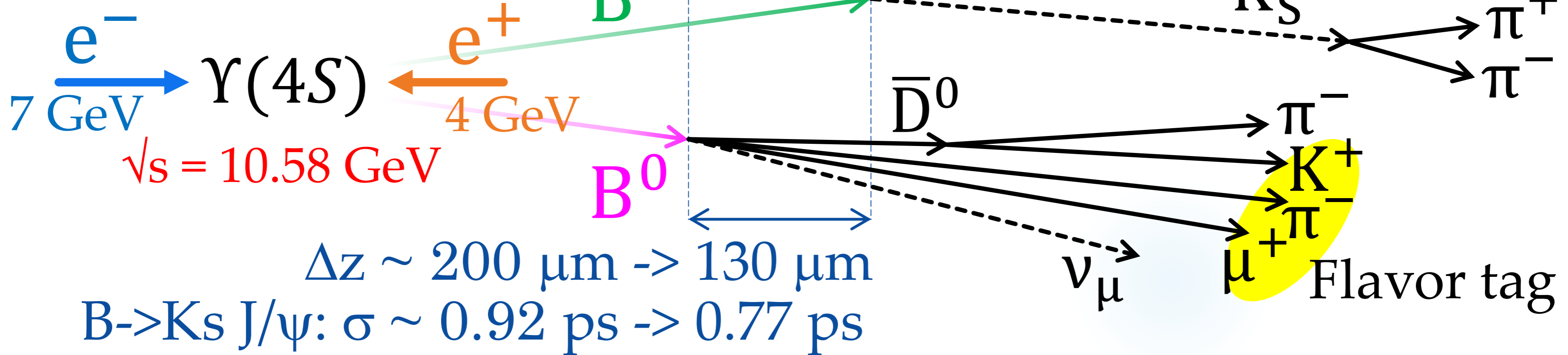

Why 10.58 GeV? Mass of $Y(4S)$ (an $n=4$ bottomonium state)

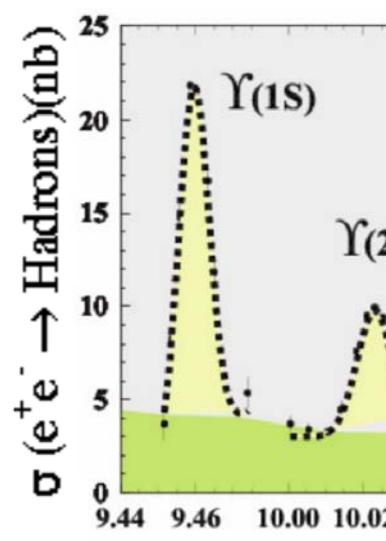

Boo
Sup

7

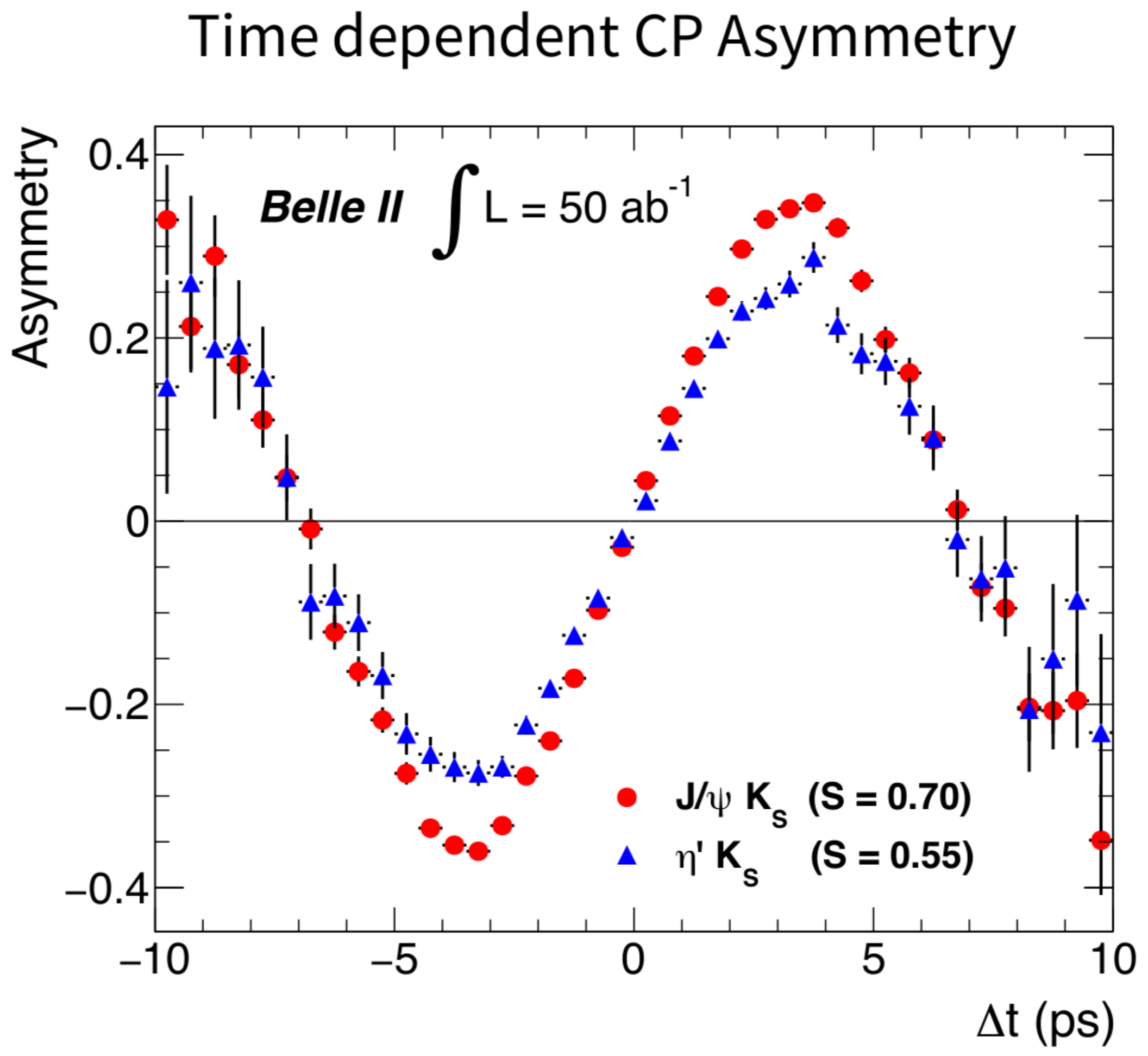

ons

τ^+
 τ^-

ag