

24th International Symposium on **P**Articles, **S**trings & **C**OSmology



June 4-8, 2018, Cleveland, USA

The Belle II Experiment: Status and Physics Prospects

Nisar Nellikunnummel (University of Pittsburgh)

(On behalf of Belle II collaboration)

The legacy of B-factories

- Belle and BaBar (1.5 ab^{-1} data) made significant contribution in understanding Standard Model (SM)

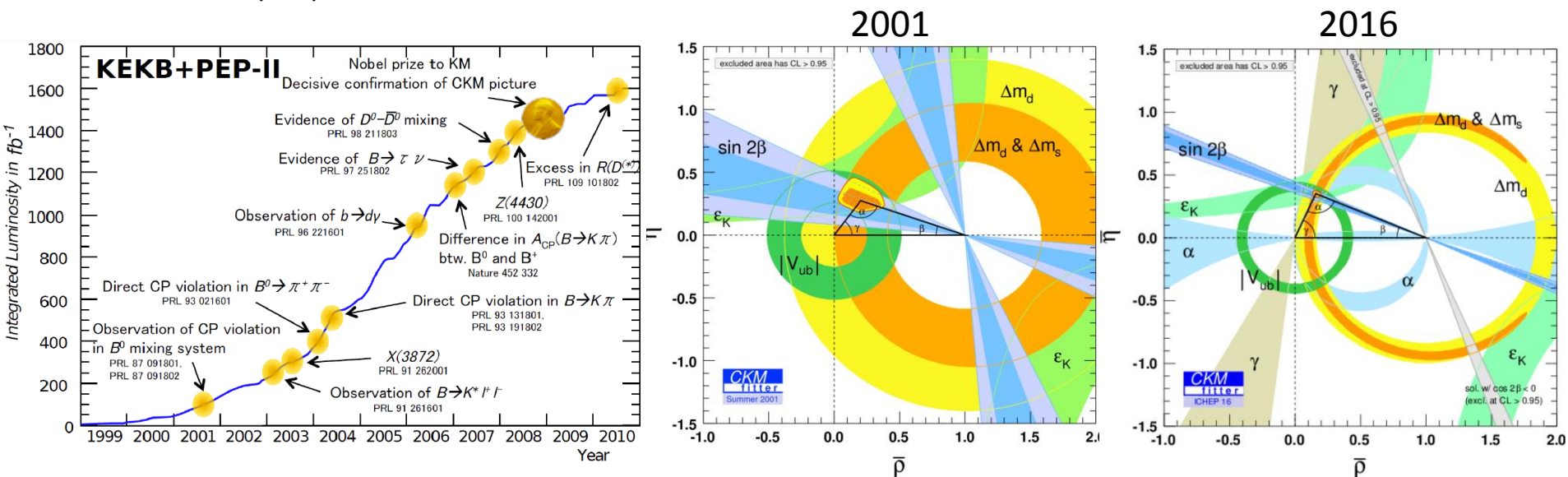

- Discovery of CP violation, an important ingredient to SM and precise measurement of CKM elements and angles of unitary triangle
- But they leave several discrepancies (between measurements and SM predictions) too
- There are more open questions: Baryon asymmetry, Dark matter/Dark energy etc.

- Belle II plan to integrate 50ab^{-1} of data ($\times 50$ Belle) by 2026
- Advantages of Belle II
 - Well understood initial state (B pairs)
 - Clean environment (e^+e^-)
 - Large sample of tau lepton
 - Better hermeticity
- Searches are complementary to other experiments (LHC) and systematic is quite different from LHCb
- Physics program
 - Indirect search for NP
 - Dark matter searches
 - Tau physics
 - A QCD laboratory for Hadron spectroscopy

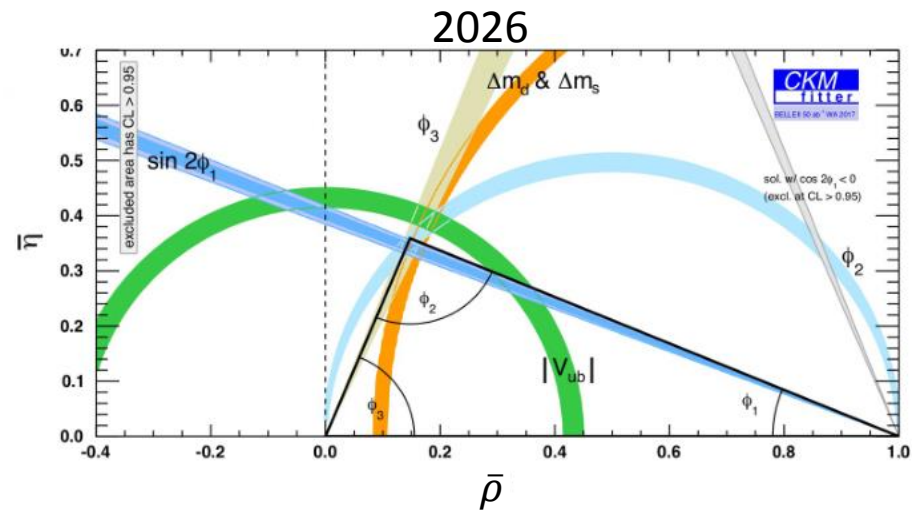
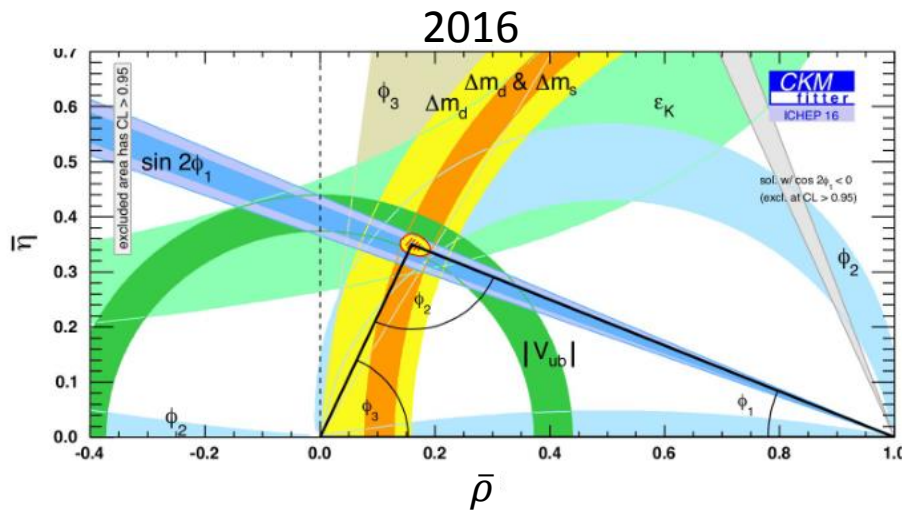

KEKB → Super KEKB

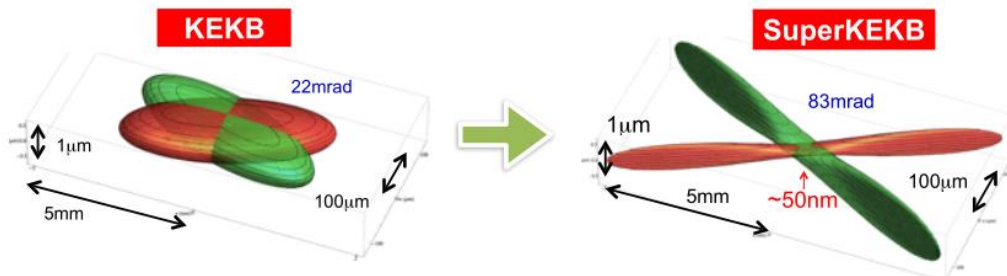

	E(GeV) HER/LER	$\beta_y^*(mm)$ HER/LER	$\beta_x^*(mm)$ HER/LER	2ϕ (mrad)	I(A) HER/LER	\mathcal{L} ($cm^{-2}s^{-1}$)
KEKB	3.5/8.0	5.9/5.9	120/120	22	1.6/1.2	2.1×10^{34}
Super KEKB	4.0/7.0	0.27/0.30	3.2/2.5	83	3.6/2.6	80×10^{34}

- Substantial upgrade of KEBK → Super KEKB
 - Reinforced RF system (higher beam current)
 - New damping ring (improve positron emittance)
 - Redesign lattice of LER&HER (reduce emittance)
 - New superconducting final focusing quadrupole magnets (QCS)

- Target Luminosity:

$$\mathcal{L} = 8 \times 10^{35} cm^{-2} s^{-1} (\times 40 \text{ Belle})$$

$$\int \mathcal{L} dt > 50 ab^{-1} \quad (\times 50 \text{ Belle})$$

- Nano-beam scheme: Squeeze vertical beta function at IP and minimize longitudinal size of overlap region

- Squeeze beam size ($\beta_{y\pm}^*$)
- Double beam current (I_{\pm})
- Larger crossing angle (2ϕ)

$$\mathcal{L} = \frac{\gamma_{\pm}}{2er_e} \left(1 + \frac{\sigma_y^*}{\sigma_x^*} \right) \frac{I_{\pm} \xi_{\pm}}{\beta_{y\pm}^*} \left(\frac{R_L}{R_{\xi}} \right)$$

X40 X2
X1/20

Belle → Belle II

- Critical issues at Super KEKB
 - Higher event rate: Fast trigger and DAQ
 - Higher background: DSP based readout (ECL) and z-vertex trigger (CDC)
- Belle II (only ECL crystals and part of KLM from Belle are reused)
 - Larger vertex detector (PXD) volume: Improved secondary vertex resolution and K_S reconstruction efficiency
 - Larger tracking volume (CDC) with higher granularity
 - New PID (TOP+ARICH): Provide better K/π separation
 - EM Calorimeter (ECL): Waveform sampling electronics to reject pile-up events

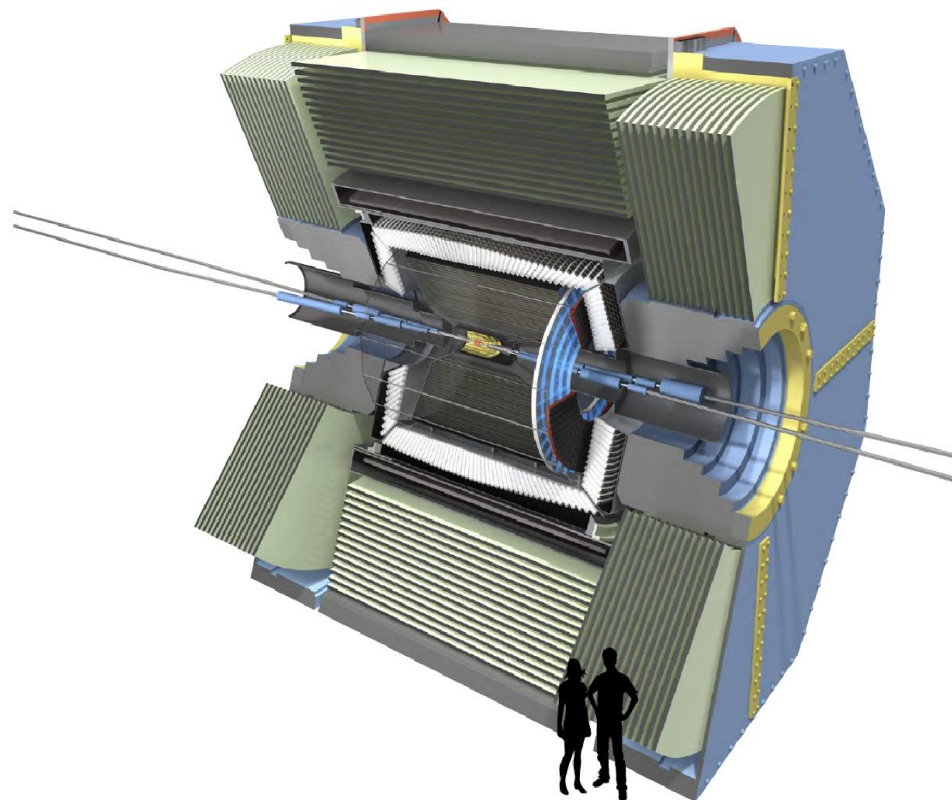

Commissioning of Super KEKB & Belle II

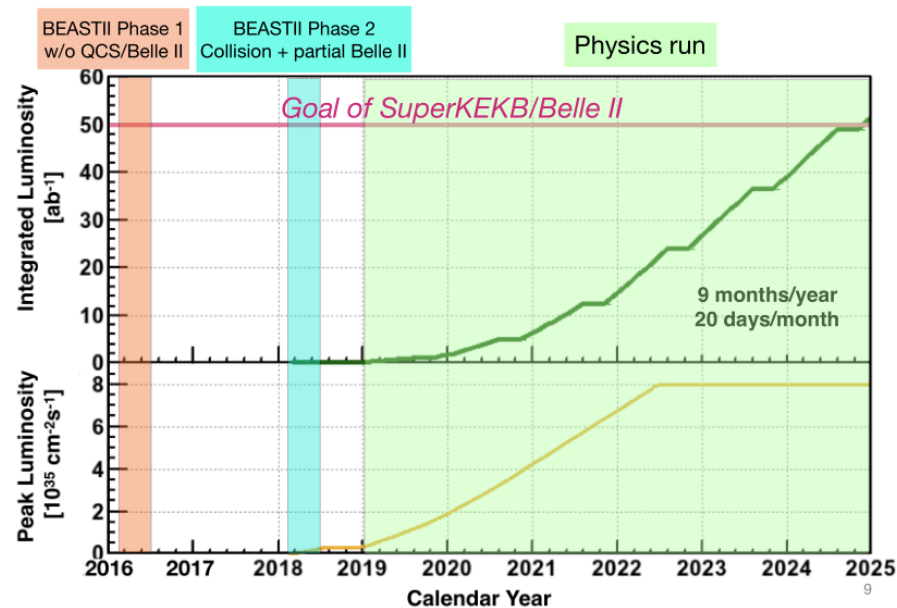

- BEAST (Beam Exorcism for A Stable Belle II experiment): commissioning detector (during Phase 1 and 2), aims to study beam induced backgrounds near IP

- Phase 1: Feb- June 2016
 1. No Belle II and no QCS magnets
 2. Beams circulate without collision
- Phase 2: March- July 2018
 1. Belle II without VXD and QCS installed
 2. VXD space occupied by BEAST
 3. First collision
- Phase 3: December 2018
 1. Physics run with full Belle II detector
 2. Operation: 9 months/year

Phase 1

Super KEKB & BEAST II

Phase 1 commissioning



- No QCS magnet → No collision
- Beam tuning (storage, vacuum scrubbing, optics studies etc.) and beam induces background study
- BEAST: Seven independent detectors are used for
 1. Thermal neutron rate
 2. Fast neutron rate and tracking
 3. Beam injection background
 4. Neutral and charged dose rate
 5. EM spectrum and dose
- First turns of Super KEKB beams achieved in March 2016
- Max. stored beam current
 - 870 mA (HER) 1010 mA (LER)
- After optics corrections, primary target of vertical emittance has been achieved in LER. More calibration is need for HER in phase 2
- First measurement of beam background at Super KEKB: <https://arxiv.org/abs/1802.01366>

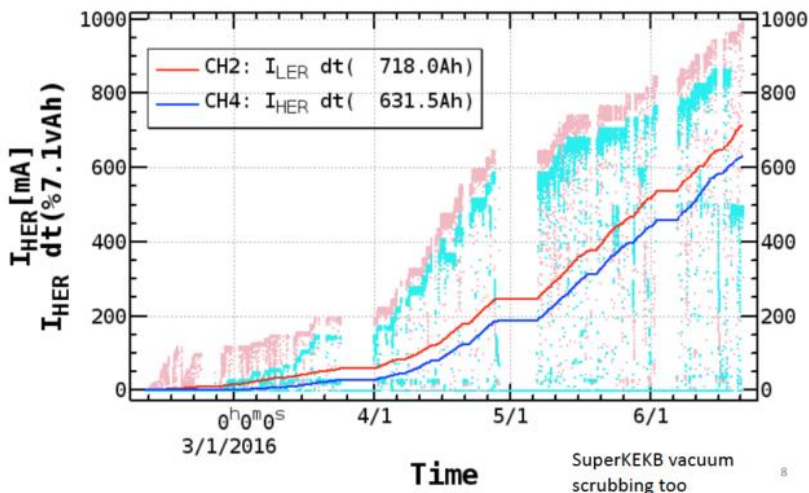

Phase 2

Super KEKB, Belle II (without VXD) &
BEAST II

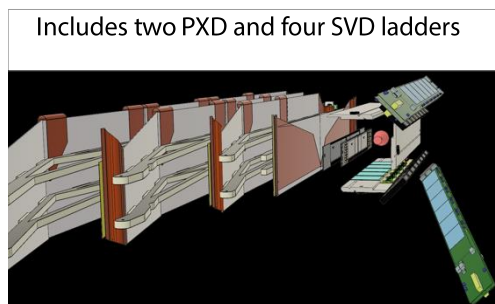
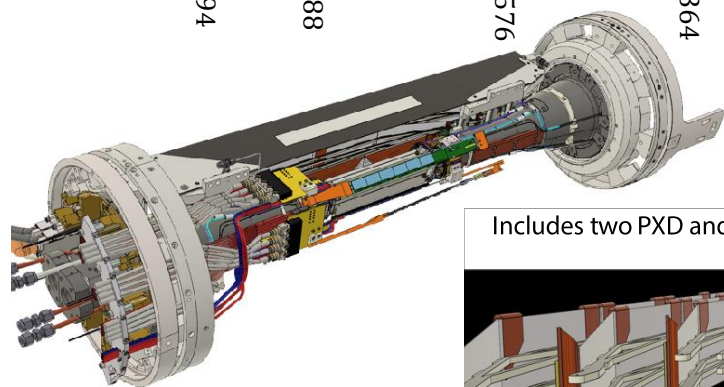
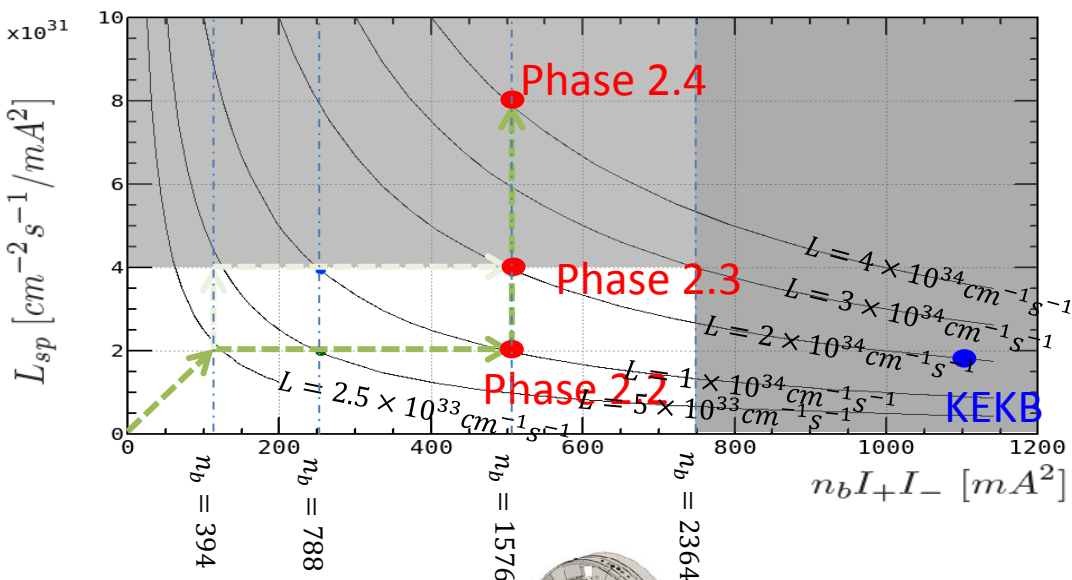

- QCS magnet installed → first collision
- Full belle II detector without VXD (occupied by BEAST II)
- Tasks
 - Squeezing beta at IP, beam collision tuning and start physics data taking
 - Ensure safe background condition for VXD
 - Measure VXD occupancies
- To measure vertex detector in-situ occupancies, ladders are installed at horizontal plane (expect highest background level) of Belle II detector
- Plan to integrate 20 fb^{-1}

Belle II installation

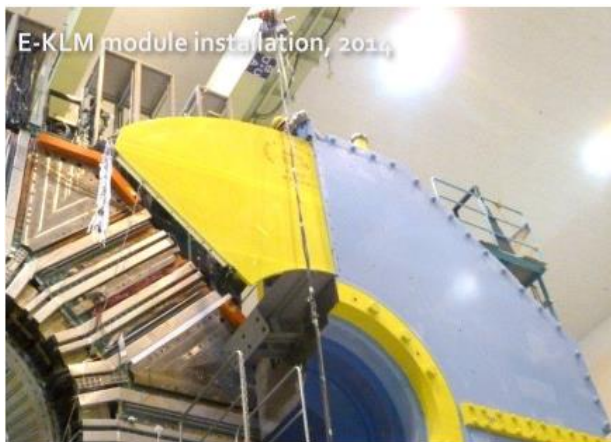

Belle II roll-in

April 11 2017

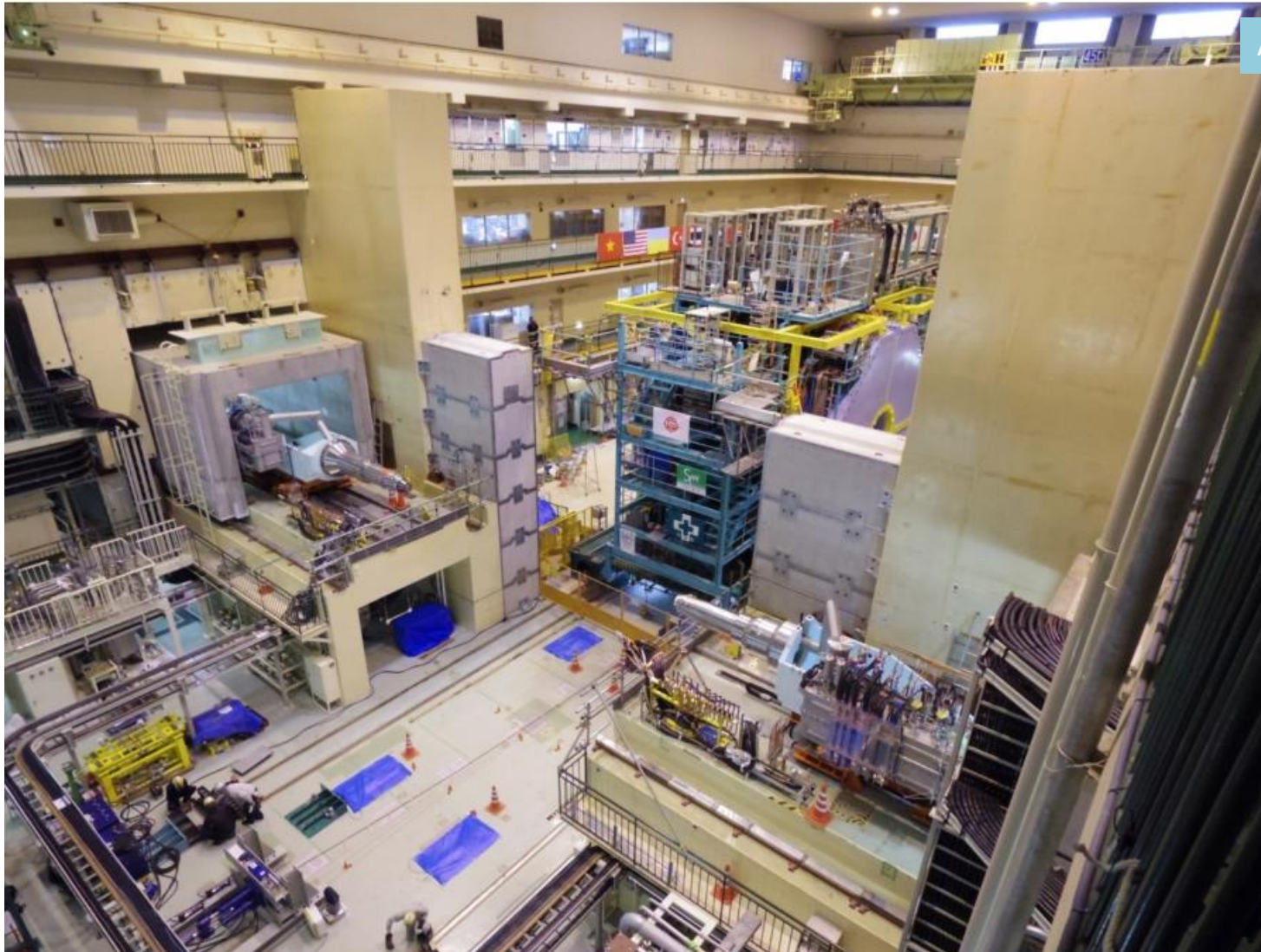

The Belle II Experiment: Status and Physics
Prospects

Trigger and DAQ

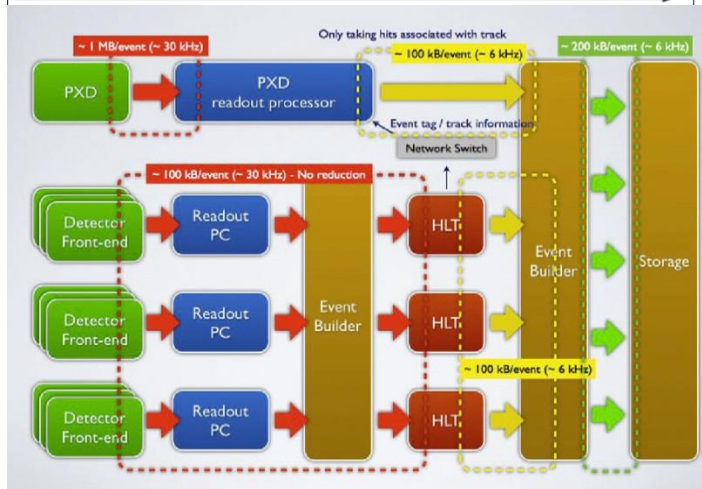
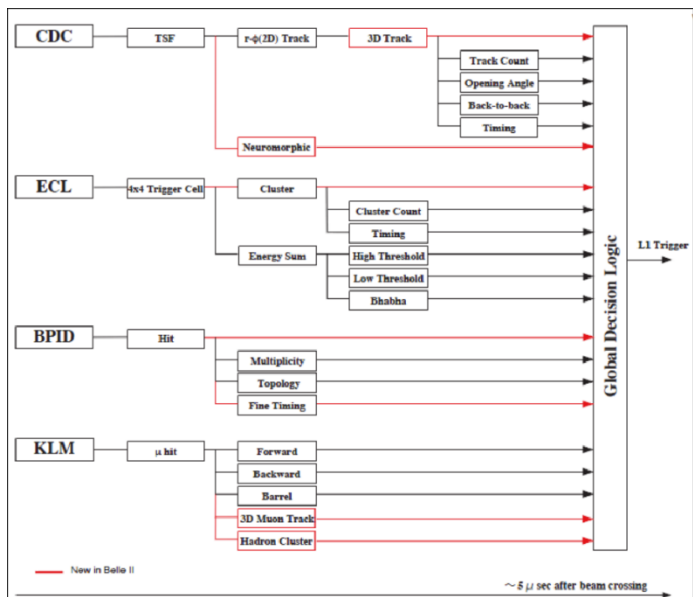

- Belle II Trigger system: L1 (Hardware Trigger)+ HLT (Software trigger)
- Challenges:
 1. Require a low multiplicity trigger (eg: Dark matter searches, τ physics) \rightarrow resembles background
 2. Reduce trigger rate due to background (to reduce data rate to DAQ)
- A novel z-vertex trigger (CDC) is designed to reject events coming from outside of IP
- L1 Features:
 - Latency $5 \mu\text{s}$
 - Trigger rate 30 kHz
- Readout integration of installed sub-detectors and central DAQ is in progress

Cosmic Run

Summer 2017

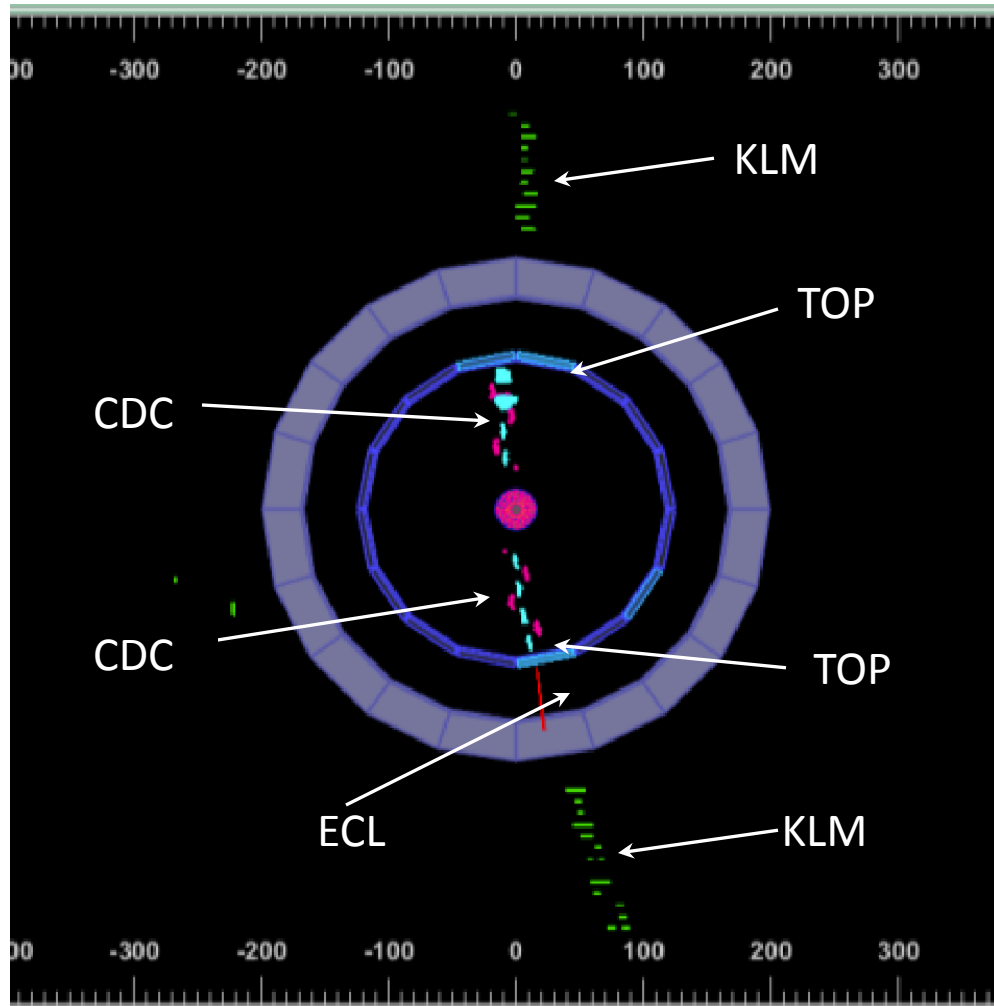

- ECL/TOP/CDC were read-out simultaneously
- Simplified trigger by ECL+CDC detector
- DAQ performance studied

First collisions

April 26 2018



The Belle II Experiment: Status and Physics Prospects

First collisions

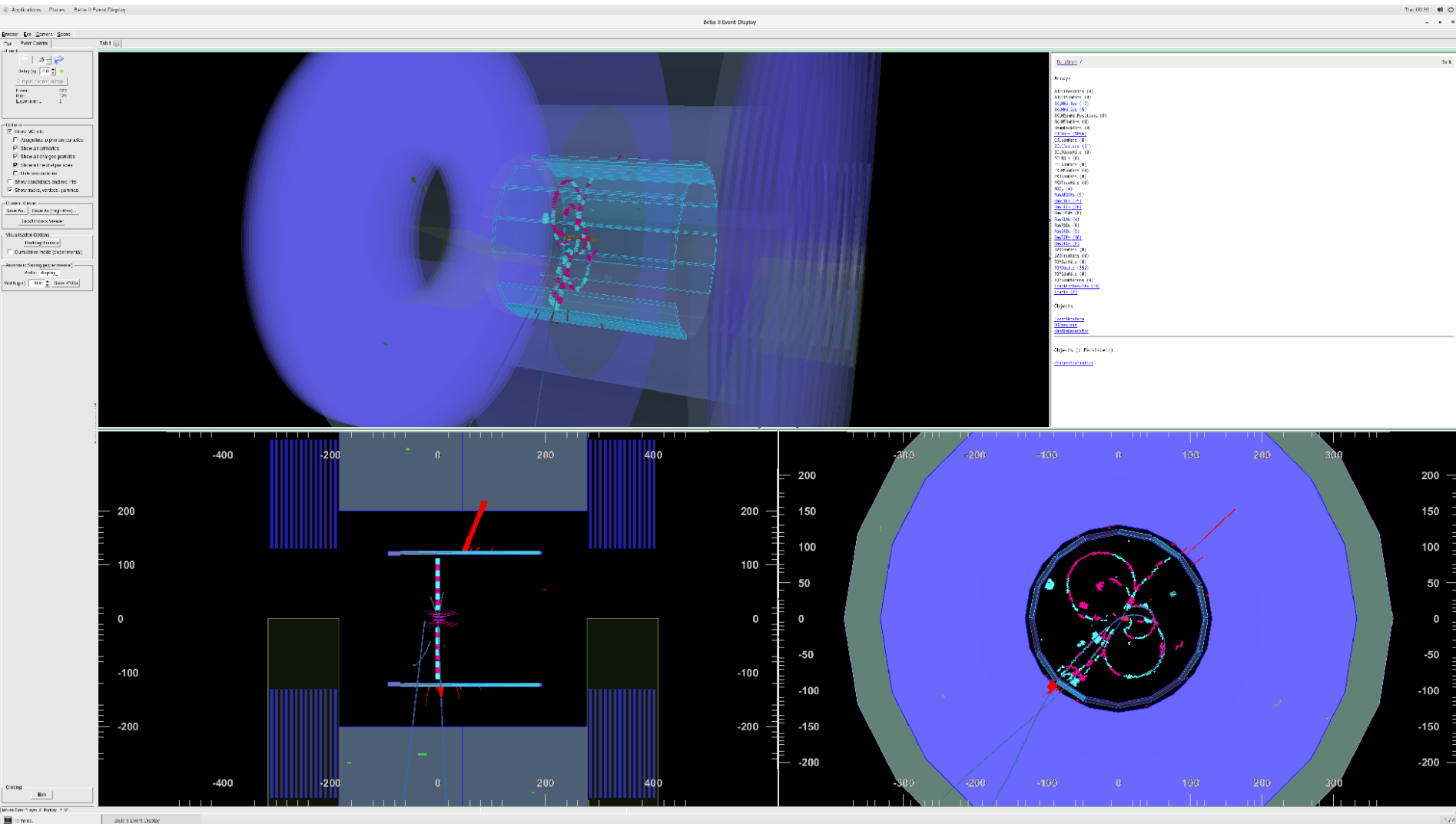

- Phase 2 data is out
- Very first mass peaks using Belle II data

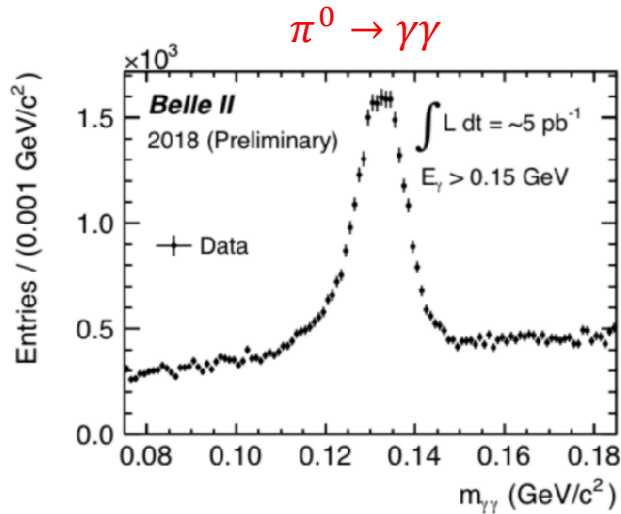

$D^* \rightarrow D^0(\rightarrow K^-\pi^+)\pi$

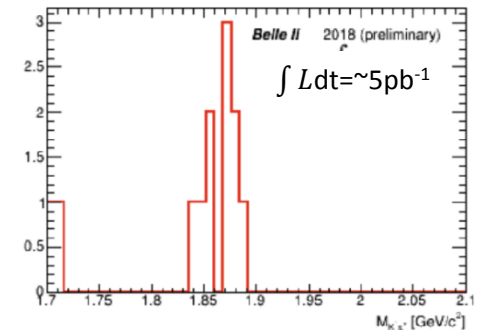
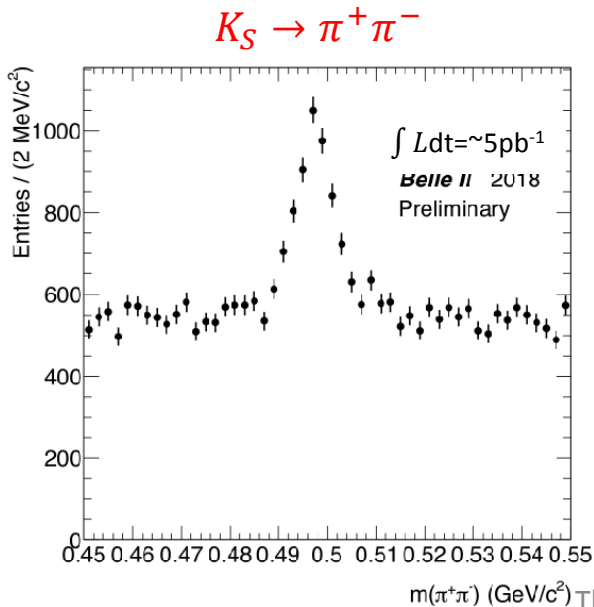
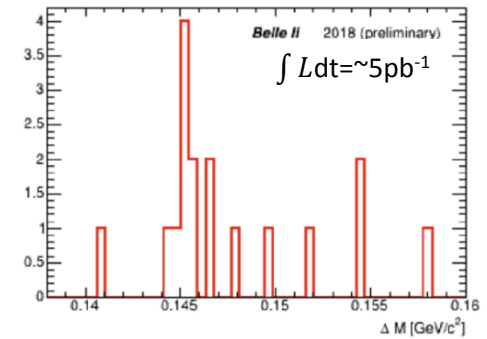
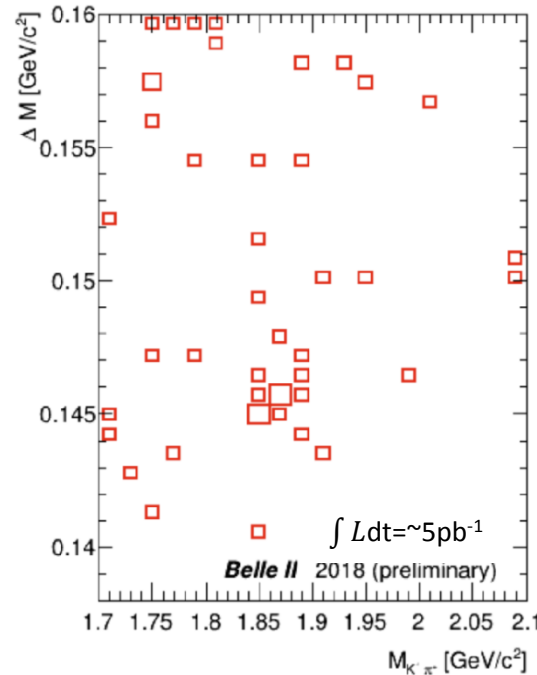

Light Dark matter search

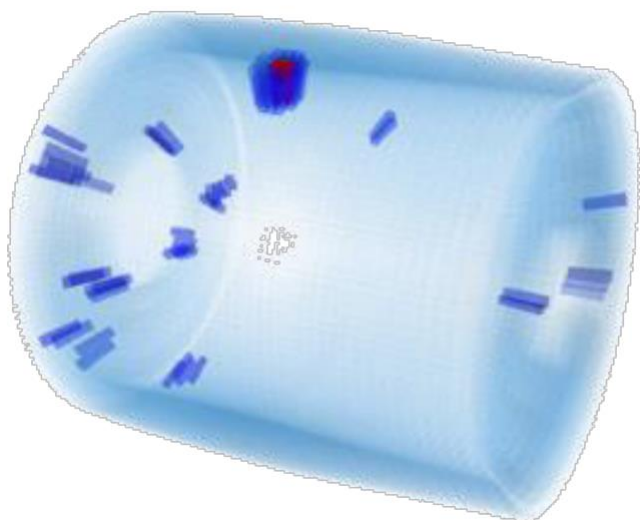
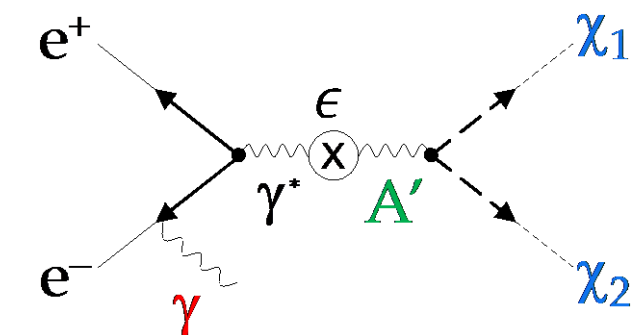

- By the end of Phase 2 we will have a small dataset without vertexing.

$$e^+e^- \rightarrow \gamma A' (\rightarrow \chi\bar{\chi}, e^+e^-, \mu^+\mu^-)$$
- Search for Dark photons based on invisibly decaying A'
- Experimental challenge: $e^+e^- \rightarrow \gamma + \text{nothing}$
 - Require low energy single photon trigger (~ 1 GeV)
 - Tracking required to veto background
- Simulations shows competitive sensitivity even with phase 2 data

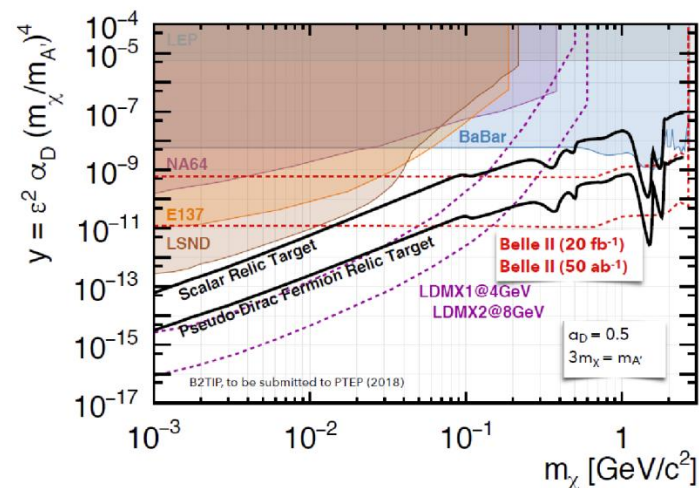

Bottomonium

PHYSICAL REVIEW D **92**, 054034 (2015)

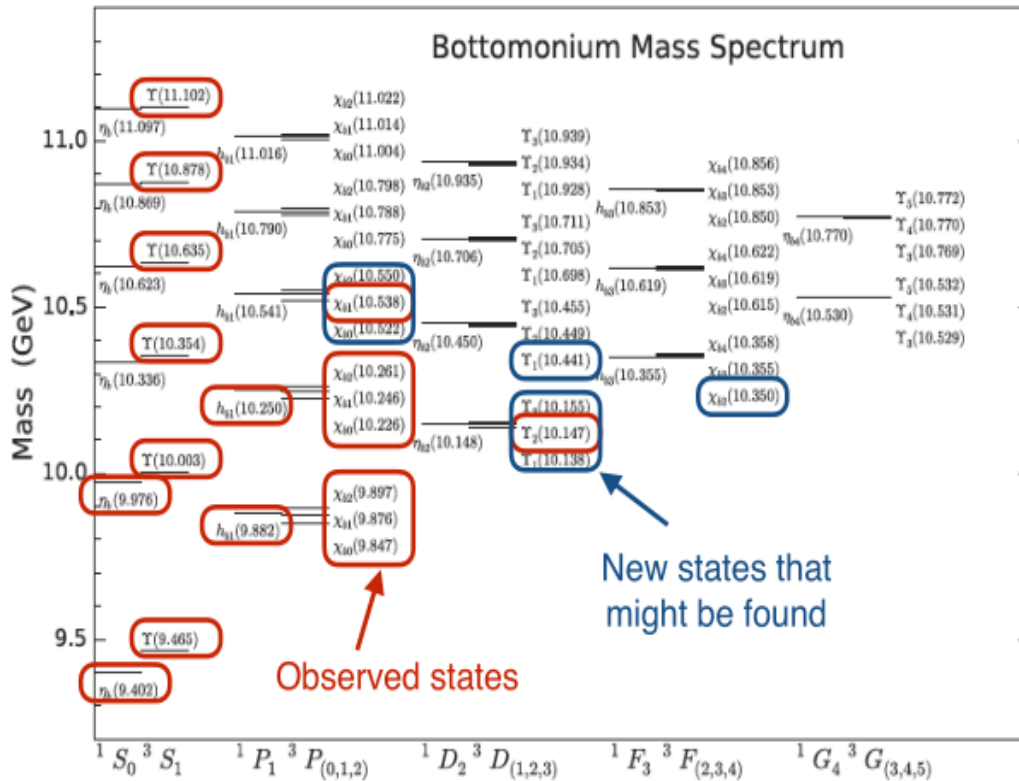

- Unique dataset at $\Upsilon(6S)$
- Investigate exotic meson states

Phase 3

Super KEKB & Belle II

- VXD
 - 2 layer Silicon pixel detector (PXD) (@ $r = 1.4, 2.2$ cm)
 - 4 layer Silicon strip detector (SVD) (@ $r = 3.8, 8.0, 11.5, 14.0$ cm)
- Compared to Belle, inner layer is closer to IP and radius of outer layer is larger → A significant improvement in the vertex resolution and reconstruction efficiency for $K_S \rightarrow \pi^+ \pi^-$
- z -vertex resolution will improve by a factor of 2
- Ladder mount is going on
- If everything goes well, phase 3 will start in Feb 2019

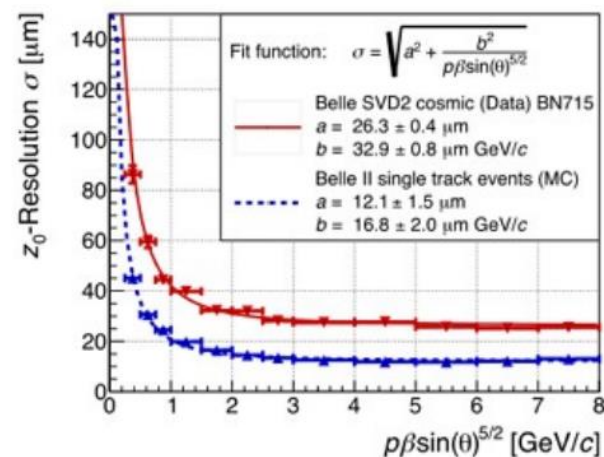
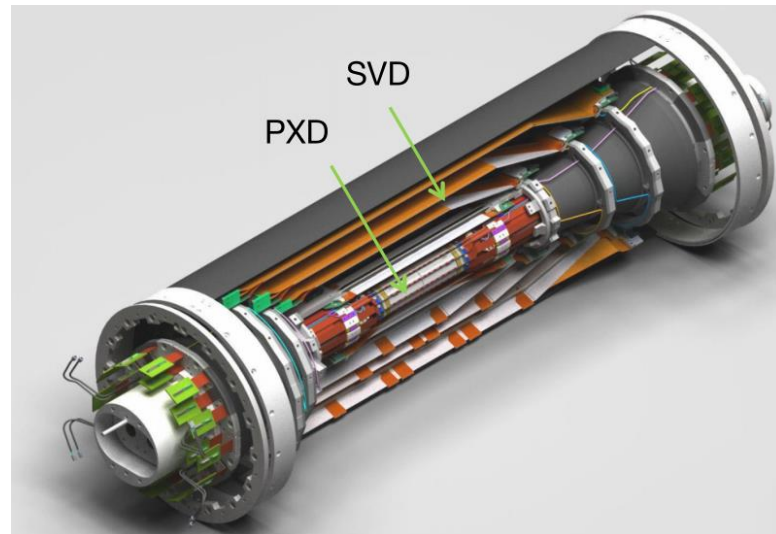

$R(D^{(*)})$

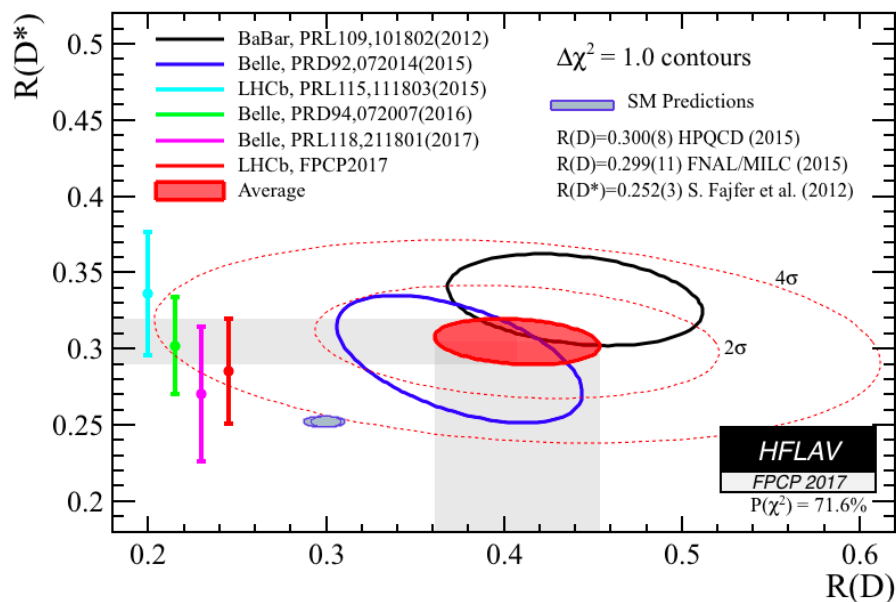

- Lepton universality: decays with e , μ and τ are identical except the effect due to different mass

$$R(D^{(*)}) = \frac{\mathcal{B}(B \rightarrow D^{(*)} \tau \bar{\nu}_\tau)}{\mathcal{B}(B \rightarrow D^{(*)} l \bar{\nu}_l)} \text{ with } l = e, \mu$$

- The ratio $R(D^{(*)})$ cancel hadronic uncertainties and systematic errors
- $R(D^{(*)})$ is sensitive to charged Higgs and Leptoquarks and hence affect decay Branching fraction
- Current WA is more than 4σ away from SM
- If the 4.1σ deviation is real, Belle II should be able to make a discovery with $5/\text{ab}$

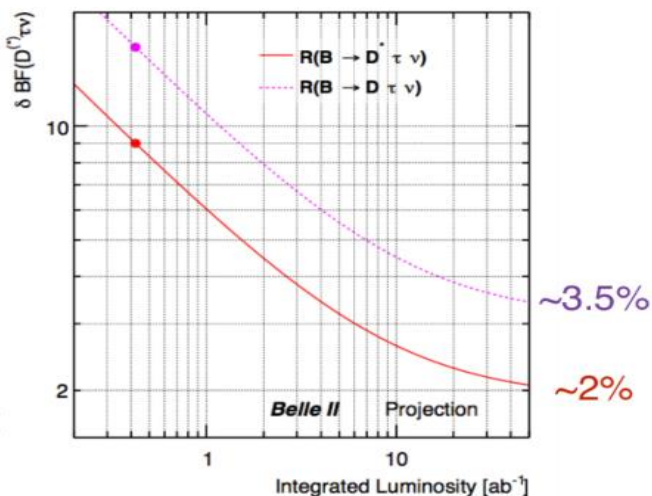

$R_{K^{(*)}}$

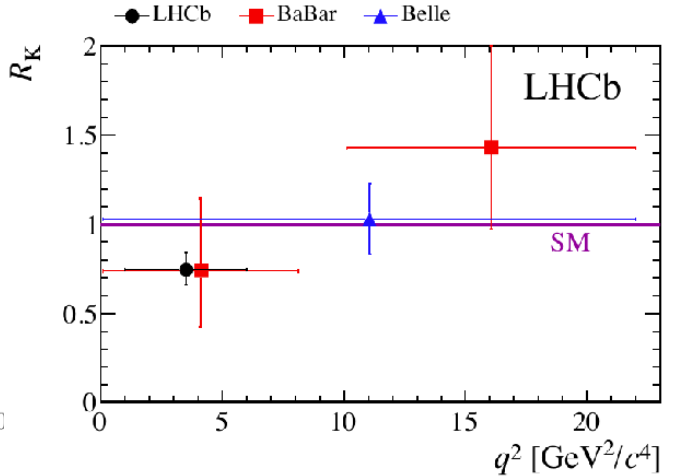
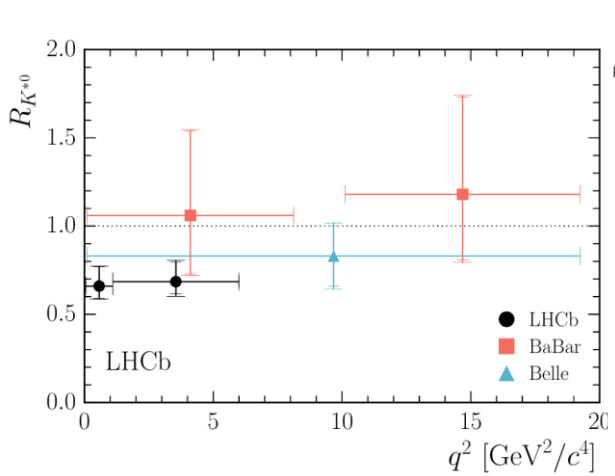

- $R_{K^{(*)}} = \frac{\mathcal{B}(B \rightarrow K^{(*)} \mu \mu)}{\mathcal{B}(B \rightarrow K^{(*)} e e)}$
- Advantage of Belle II
 - Electron and muon modes have same efficiency
 - Both low and high q^2 regions are possible
 - $R_K, R_{K^{(*)}}$ and R_{X_S} can be measured

- 2.6 sigma deviation from SM by LHCb
- If it is real, Belle II should be able to make a 5sigma discovery with 20ab^{-1}

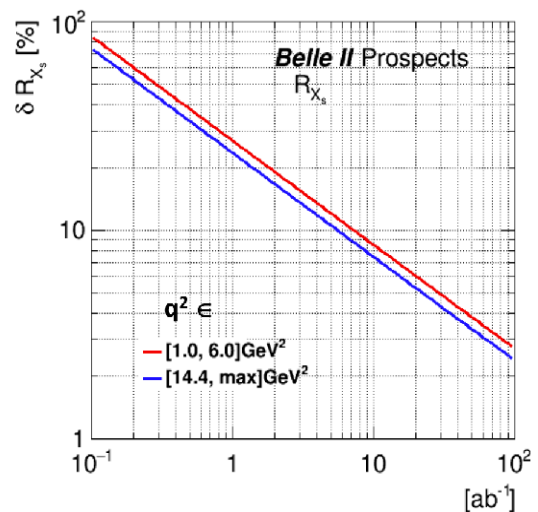
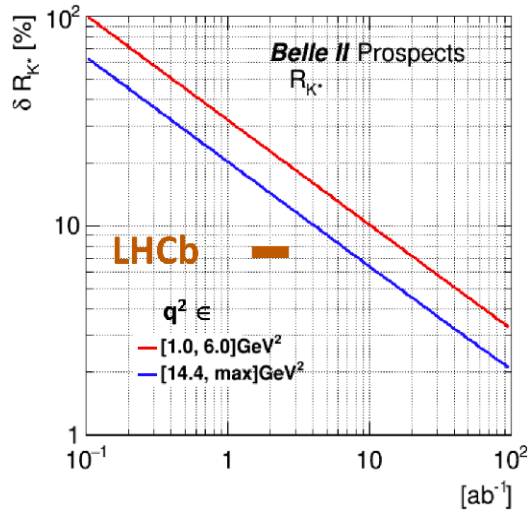
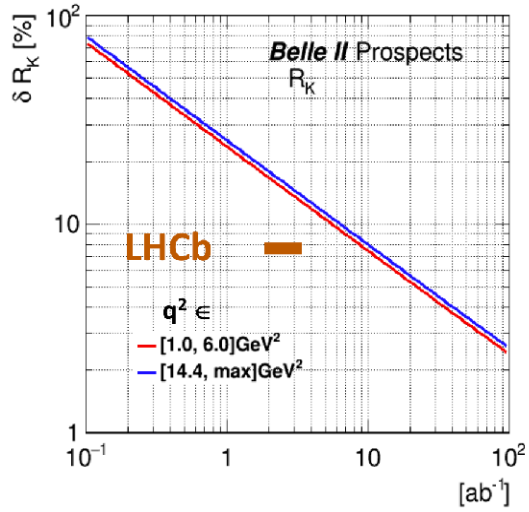

Prospects

$$B^+ \rightarrow \tau^+ \nu_\tau$$

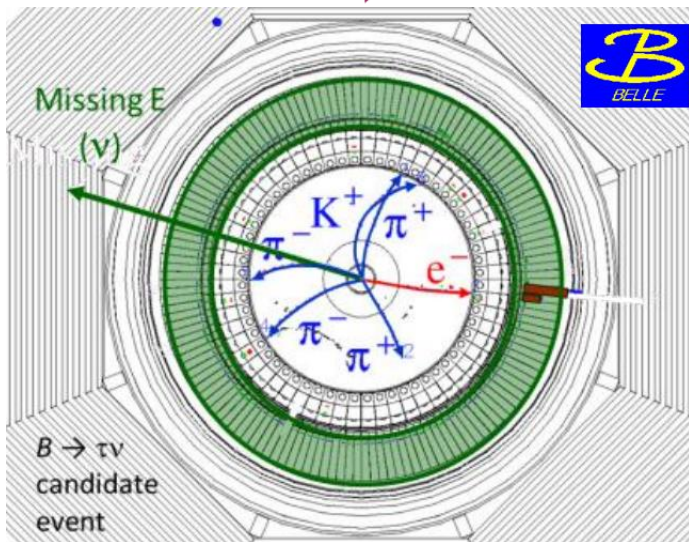
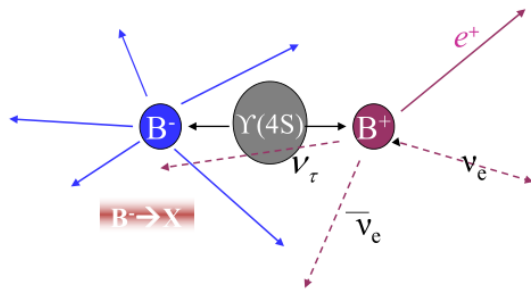
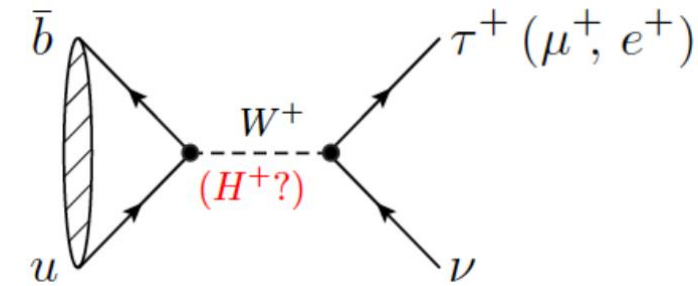

- Decay with large missing energy
- Experimentally challenging:
 - $B^+ \rightarrow$ single charged track + nothing (Clean e^+e^- environment make this possible)
- Helicity suppressed \rightarrow Branching ratio strongly depend on mass of lepton ($B^+ \rightarrow \tau^+ \nu_\tau$ has largest \mathcal{B})
- Charged Higgs breaks lepton universality
- Significant enhancement or suppression of \mathcal{B} is expected by exchange of charged Higgs (type II 2HDM) (W.S.Hou, PRD 48, 2342(1993))
- World average $\mathcal{B} = (1.09 \pm 0.24) \times 10^{-4}$
- No deviation from SM so far With Belle II (50 ab^{-1})sensitivity will reach $\sim 6\%$

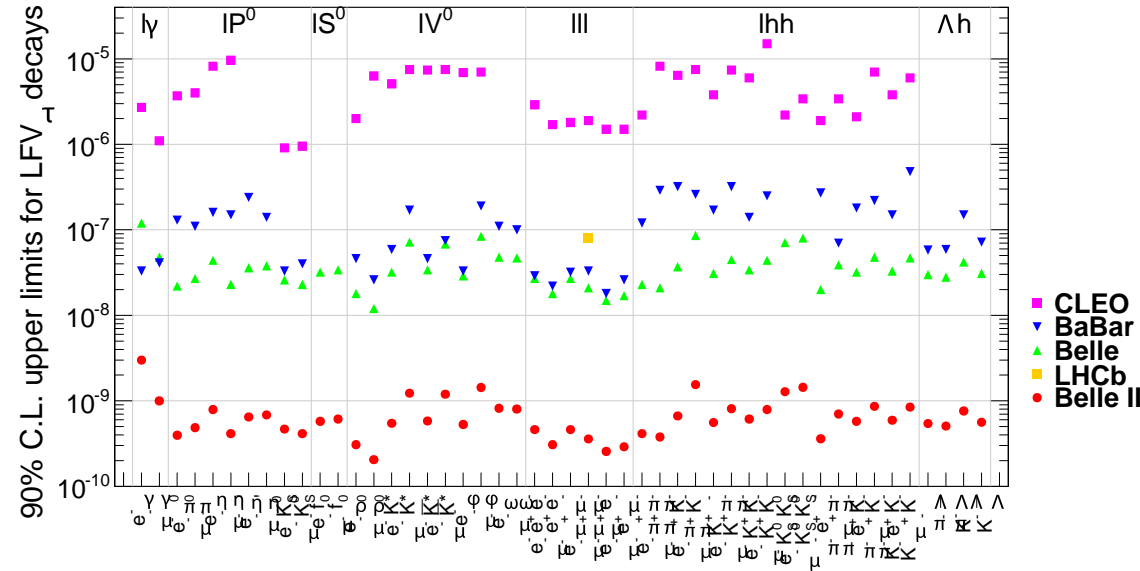

- In SM LFV is highly suppressed $\mathcal{O}(10^{-54})$
- Many LFV decays are allowed for τ lepton in NP models
- Belle collected $10^9 \tau$ pairs while Belle II expect $5 \times 10^{10} \tau$ pairs with its full data set
- LFV sensitivity will depend on the level of background in Belle II
 - Background free modes like $\tau \rightarrow 3l$ can reach a sensitivity of $\mathcal{O}(10^{-10})$ for branching ratio
 - $\tau \rightarrow \mu\gamma, e\gamma$ (challenge: irreducible background from $e^+e^- \rightarrow \tau\tau\gamma$)

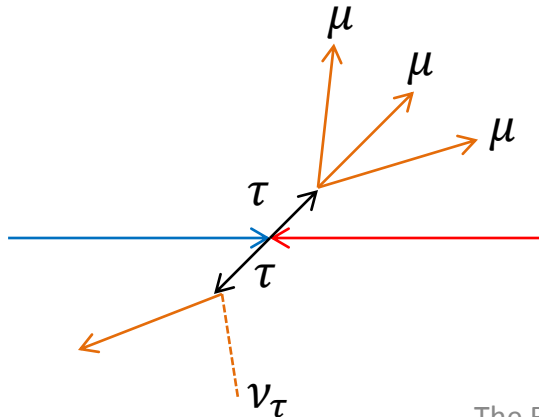



Summary

- First turns of Super KEKB beams achieved in March 2016
- Belle II roll-in April 2017
- Belle II recorded first collision on April 26, 2018
- Phase 2 data is available for physics study
- Physics run with full Belle II in early 2019

- Compared to Belle, extend outer radius and smaller cells.
- Faster readout electronics
- The drift chamber is fully constructed and installed in the Belle II detector and commissioned with cosmic rays
- 3D track trigger: Provide z-vertex trigger to suppress events coming outside of IR

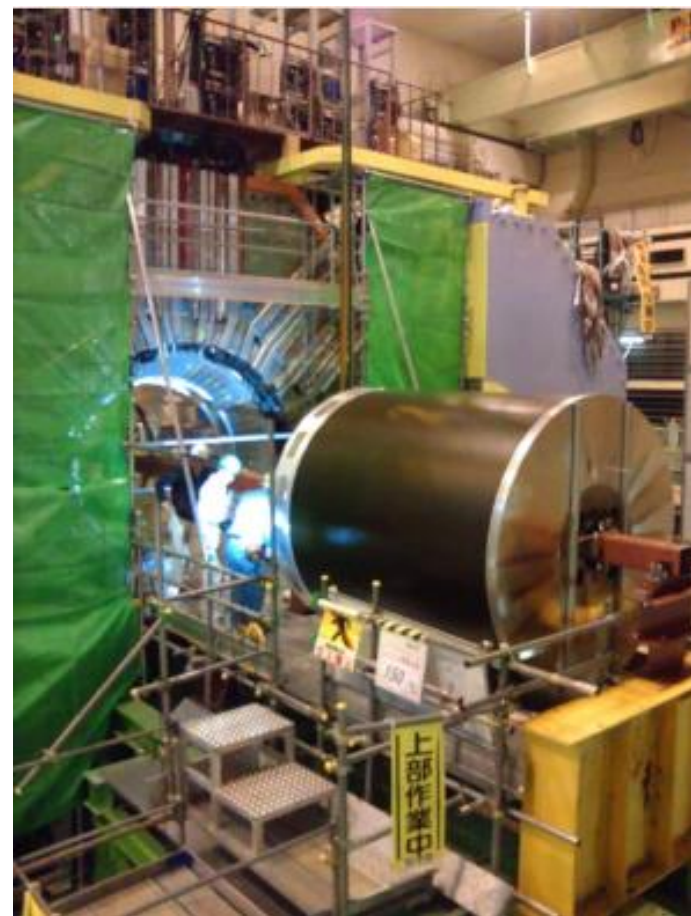

	Belle	Belle II
Inner radius (mm)	88	168
Outer radius (mm)	863	1111
No. of layers	50	56
No. of sense wires	8400	14336
Gas	He-C ₂ H ₆	He-C ₂ H ₆
Diameter of sense wire(μm)	30	30

- Charged particles hitting on Quartz radiator produce Cherenkov photons
- Photons undergo total internal reflection and eventually detected by array of MCP-PMTs → space resolution 5mm
time resolution 40ps
- Image in space-time → particle identification
- Also acts as time of flight detector

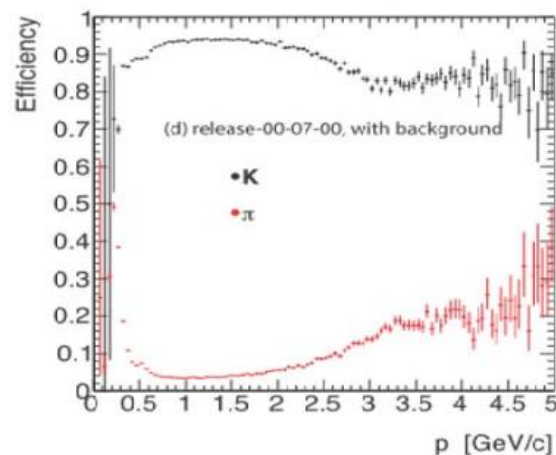
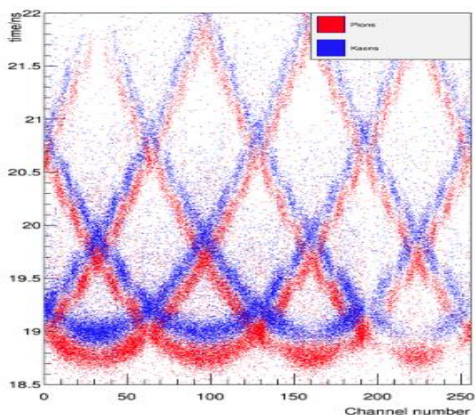
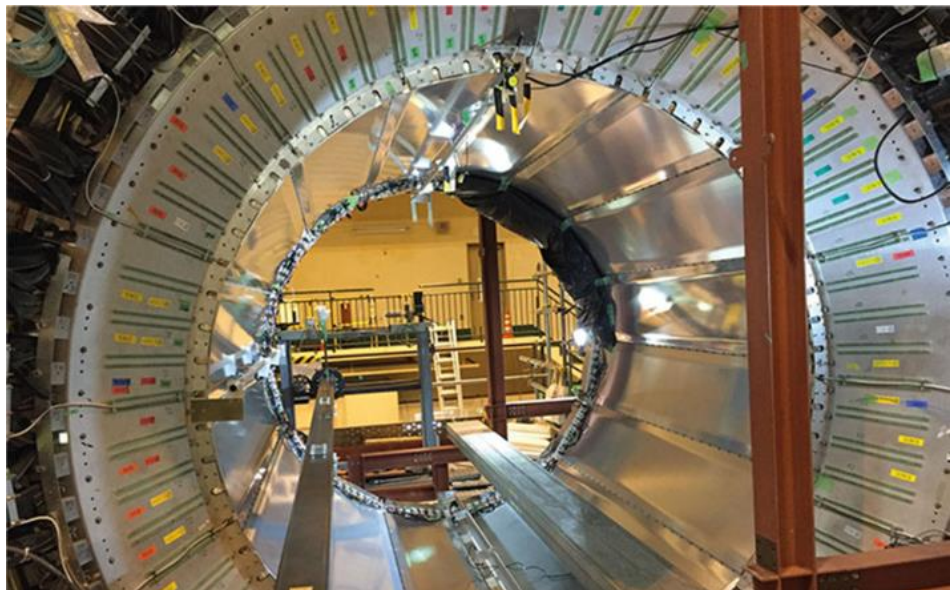

ARICH (End cap PID)

2017 Oct

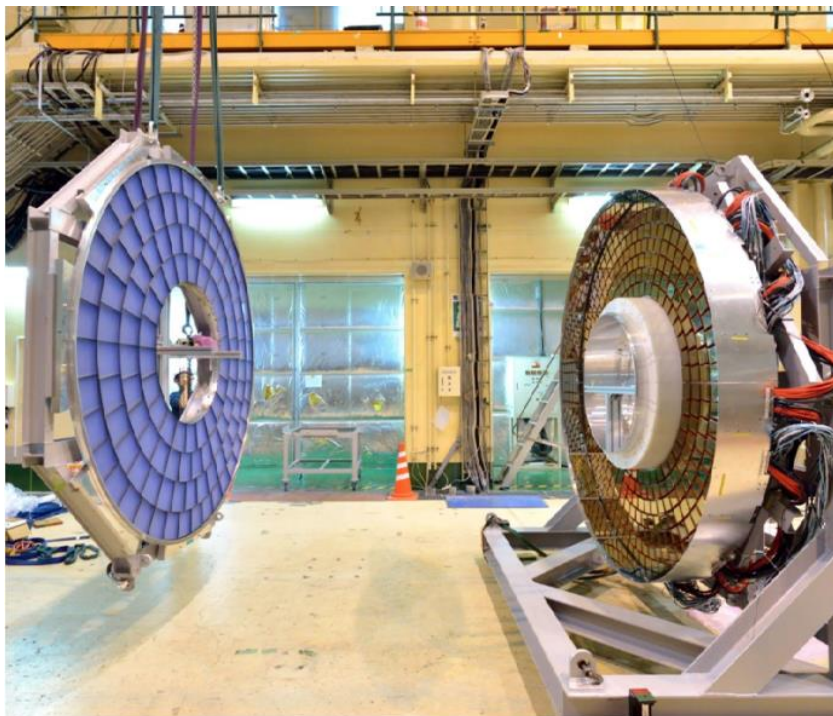

- Silica Aerogel radiators ($n=1.045-1.055$)
- Hybrid Avalanche Photo Detectors are used for photon detection
- K/π separation: 6σ at 4 GeV/c
- It is combined with endcap ECL and installed October 2017

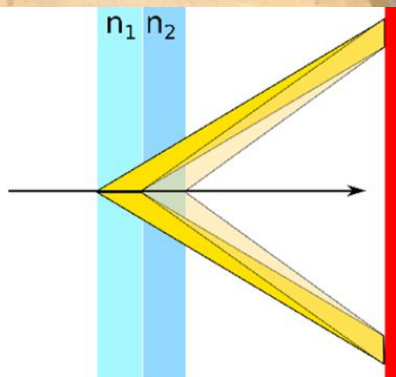

Proximity focusing

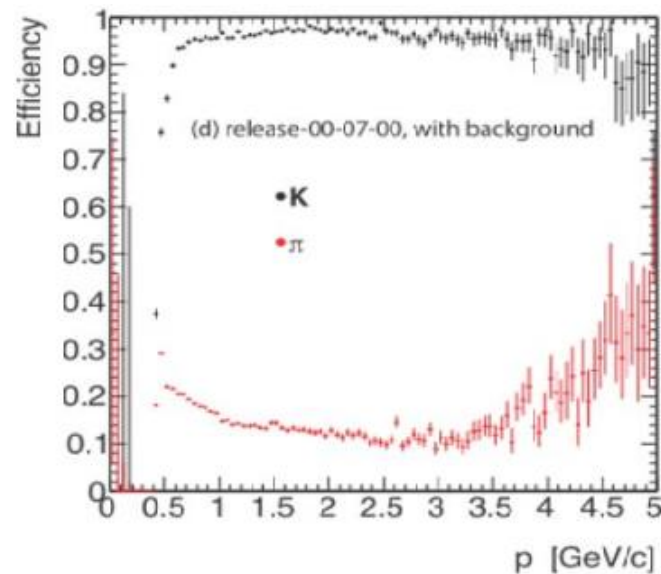

EM Calorimeter



- Belle CsI(Tl) crystals are reused
- High event rate and long decay time of CsI(Tl) crystals
 - overlapping of pulses from neighboring events
 - fake clusters and pile-up noise
- Wave form sampling readout electronics to reject off time hits (1.76 MHz, 18 bit digitizer)
- Fit waveform to extract energy (amplitude) and timing

prototype tested at Belle

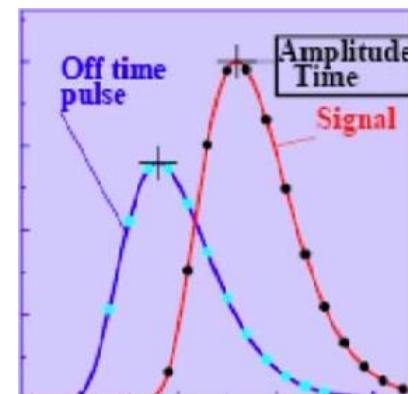
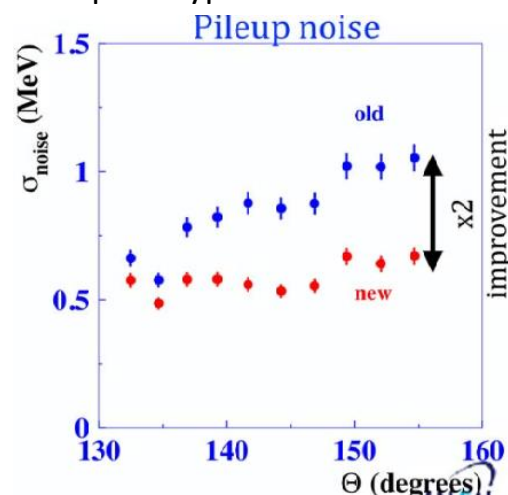



- In Belle, 15 active layers in barrel and 14 in endcap
- Active layers are Resistive Plate Chambers (RPC)
- To cope with higher background, endcap and two inner layer of Belle were replaced with scintillators in Belle II.
- Scintillator strips readout with WLS fiber and SiPM

